

苏州工业园区天地链条有限公司  
S. I. P. TIANDI CHAIN Co., Ltd

苏州市格雷特链传动有限公司  
SUZHOU GREAT CHAIN TRANSMISSION Co., Ltd

苏州天地链条

输送链专业制造商

since 2004



2019



### 盖板形状 U type attachments Shape

普遍型  
Universal type



平的  
Flat

C型  
C type



缺口、平的  
Gap、Flat

D型  
D type



缺口、下凹  
Gap、Concave

橡胶性能汇总表

橡胶名称	丁晴	硅	聚氨酯	氟	天然	异戊	顺丁	丁苯	丁基	乙丙	乙烯- 醋酸乙 烯共聚	氯丁	氯磺化 聚乙烯	氯化聚 乙烯	氯醇	硝戊	聚丙烯 酸酯	聚硫
常见缩写	NBR	SI	PU	FPM	NR	IR	BR	SBR	IIR	EPDM	EVA	CR	CSM	CPE	CHR	NIR	ACM	T
硬度 (邵氏A)	15-100	30-90	10-100	50-90	10-100	20-100	30-100	30-100	20-90	30-90	50-90	10-90	50-90	50-85	20-90	15-100	40-90	30-90
扯断强度, kg/cm <sup>2</sup>	50-250	40-100	200-450	70-200	30-300	50-200	20-200	50-200	50-150	50-200	70-200	50-250	70-200	70-200	-	100-300	70-120	30-150
伸长率, %	100-800	50-500	300-800	100-500	100-1000	100-1000	100-800	100-800	100-800	100-800	100-600	100-1000	100-500	100-800	-	100-900	100-600	100-700
弹性	B	A	A	C	A	A	A	B	C	B	B	A	B	B	B	B	C	C
抗撕裂强度	B	C-D	A	B	A	B	B	C	B	C	B	B	B	B	B	B	C	C-D
压缩永久变形	A	A	A	B	A	A	B	B	C	B	B	A	B	B	B	B	D	D
耐磨性	A	C-D	A	A	A	A	A	A	B	B	B	A-B	A	A	B	A	B	C-D
耐曲折龟裂性	B	B-D	A	B	A	A	C	B	A	B	B	B	B	B	-	B	B	D
耐热性 (最高使用温度)	120	250	80	250	100	100	100	150	150	150	100	120	150	150	150	120	160	80
耐寒性 (脆性温度)	-20	-120	-60	-20	-70	-5-70	-70	-60	-55	-60	-30	-55	-60	-	-40	-10	-30	-40
耐老化性	B	A	B	A	B	B	B	A	A	A	A	A	A	A	A	A	A	B
耐臭氧性	D	A	A	A	D	D	D	A	A	A	A	B	B	A	A	D	A	A
耐光、耐候性	B	A	A	A	B	B	B	A	A	A	A	A	A	A	A	B	A	A
耐燃性	C-D	B-D	C-D	A	D	D	D	D	D	D	D	B	B	B	B	C-D	C-D	D
不透水性	B	D	B	A	B	B	B	C	A	A	A	B	A	B	A	B	B	A
耐辐射性	B-D	A-C	B	B-C	B-C	B-C	D	B	D	B	B	B-C	B-C	-	-	B-D	B-D	B-C
汽油	A	C-D	A	A	D	D	D	D	D	D	D	D	B	B	B	A	A	A
苯、甲苯	C-D	C-D	C-D	A	D	D	D	D	C	C	D	D	C-D	C-D	C-D	C-D	D	B
三氯乙烯	D	B-D	D	B	D	D	D	D	D	D	D	D	D	D	D	D	D	B-C
酒精	A	A	C	A	A	A	A	A	A	A	C	A	A	A	A	A	D	A
甲乙酮, 醋酸乙酯	D	B	D	D	B-C	B-C	B-C	B-C	A	A	D	B-C	C	C	D	D	D	A
强酸	B	C	D	A	C	C	C	C	A	B	B	B	A	A	B	B	C	D
弱酸	B	B	C	A	B	B	B	B	A	A	B	A	A	A	B	B	B	C
强碱	B	A	D	D	B	B	B	B	A	A	A	A	A	A	B	B	C	C
弱碱	B	A	D	C	B	B	B	B	A	A	A	A	A	A	B	B	B	C



# 平板链

## Roller chain with flat attachments

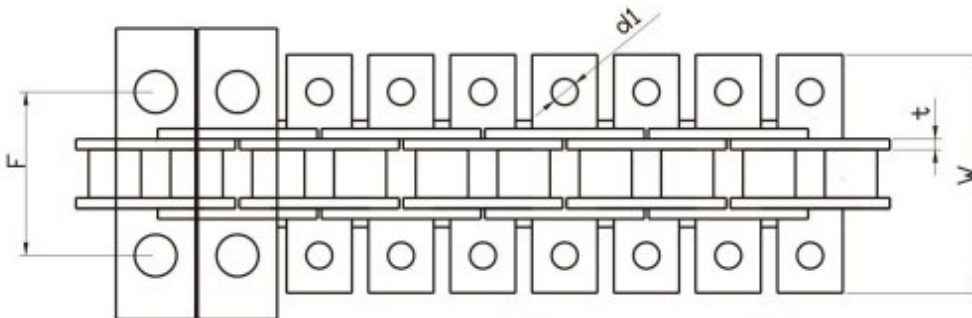
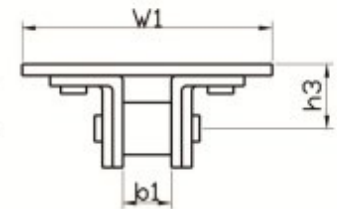
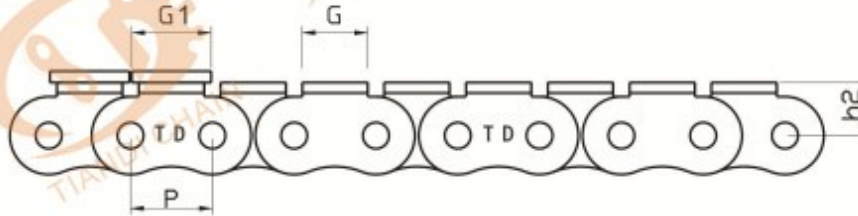

天地型号	节距 Pitch	滚珠直径 Roller diameter	销轴直径 Pin diameter	附板尺寸 attachment size								厚度 plate thickness
Chain No.	P	d1 max	d2 max	G	G1	W	W1	h2	h3	d1	F	T
	mm	mm	mm	mm	mm	mm	mm	mm	mm	mm	mm	mm
08B-PB	12.7	8.51	4.45	9.5	12	36.4	55	8.9	10.4	4.5	25.4	1.5
08B-PB F1	12.7	8.51	4.45	9.5	12	36.4	50	8.9	10.4	4.5	25.4	1.5
08B-PB F2	12.7	8.51	4.45	9.5	12	36.4	40	8.9	10.4	4.5	25.4	1.5
12A-PB	19.05	11.91	5.94	15.9	16	56.8	80	11.9	14.3	6.8	40	2.4
12A-2 PB F1	19.05	11.91	5.94	15.9	33	77	85.5	11.9	14.3	5.5	60.88	2.4

# U型盖板链(单排) Roller chain with U type attachments(simpex)

加外片 A Type  
with outer plate

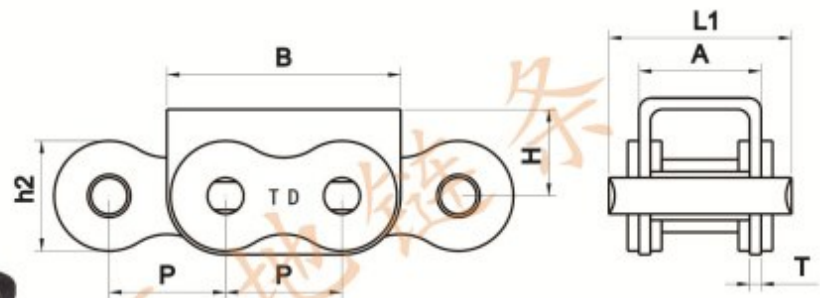

不加外片 B Type  
without outer plate

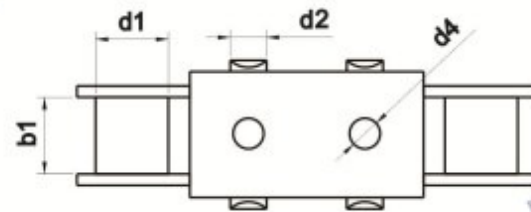
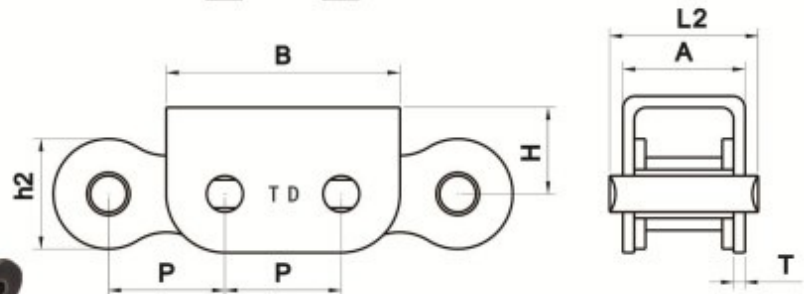
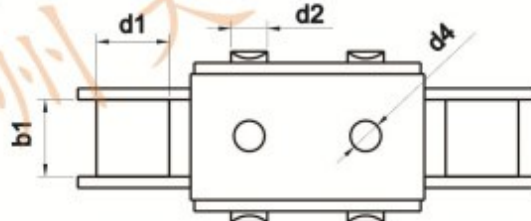

天地型号 Chain No.	节距 Pitch P	滚珠直径 Roller diameter d1	内节内宽 Width between inner plates b1	销轴直径 Pin diameter d2	链片宽度 Plate depth h2	销轴长度 Pin length		U板尺寸 U plate size				形状 Type	U板厚度 U plate thickness T	极限抗拉强度 Ultimate tensile strength Q min	每米重量 Weight per meter q
						A Type	B Type	A	B	H	d4				
04C-U1	6.35	3.3	3.18	2.31	6	10.6	8.9	7	11.6	9.4	-	-	1	3.5/795	0.35
06B-U1	9.525	6.35	5.72	3.28	8	16.1	13.2	11.4	17.3	5.2	-	-	1.3	9/2045	0.7
08A-U1	12.7	7.95	7.85	3.96	12	19.4	16.6	14.2	24.2	8.3	4	-	1.5	14.1/3205	1.09
08B-U1	12.7	8.51	7.75	4.45	11.8	19.8	16.7	14.6	24.2	8.3	4	-	1.6	18/4091	1.13
10A-U1	15.875	10.16	9.4	5.08	15	23.5	20.6	17.4	30	12	5	-	1.5	18/4123	1.6
10B-U1	15.875	10.16	9.65	5.08	14.7	23	19.5	16.8	30	11.3	5	-	1.5	19/4318	1.53
12A-U1	19.05	11.91	12.57	5.94	16	30.7	25.9	21.4	36	13	5	-	1.85	27/6291	1.97
12B-U1	19.05	12.07	11.68	5.72	16	26.7	22.5	19.6	36	13	5	-	1.85	29/6591	1.9
16A-U1	25.4	15.88	15.75	7.92	24	37.2	31	27.5	47.5	16	7	-	2.42	42/9545	3.87
16A-U1F1	25.4	15.88	15.75	7.92	24	37.2	31	27.5	50.2	16	7	-	2.42	42/9545	3.92
16B-U1	25.4	15.88	17.02	8.28	21	39.7	33.7	29.05	49	15.4	6	-	1.5	58/13407	3.73
20A-U1	31.75	19.05	18.9	9.53	30	46	48	34.5	57	21.8	6.5	-	3	88.5/20114	5.9
20B-U1	31.75	19.05	19.56	10.19	26.4	48	41	36	57	21	8	-	3.5	85/19318	6.01
24A-U1	38.1	22.23	25.22	11.1	35.7	58.3	50.3	41	69	27.5	-	-	3	127/28864	9.6
24B-U1	38.1	25.4	25.4	14.63	33.2	61.6	52	47	72.6	28	10	-	4.5	160/36363	10.88
32A-U1	50.8	28.58	31.55	14.27	47.8	76.2	-	58.2	101	50	-	-	6.4	226.8/51545	
P27.5	27.5	11.91	12.57	5.94	16	30	25.7	23.5	45.5	13	6	-	2	27/6291	
P28.5	28.5	10.16	9.65	5.08	15	19.5	-	17	41.3	12.1	6	-	1.7		
C2050-U1	31.75	10.16	9.4	5.08	15	24	20	17.4	34.5	12	5	-	1.5	22.2/5045	
C2080-U1	50.8	15.88	15.75	7.92	24	40.5	32.5	29	68	22	-	-	3		



# U型盖板链(双排) Roller chain with U type attachments(duplex)



加外片 A Type  
With outer plate

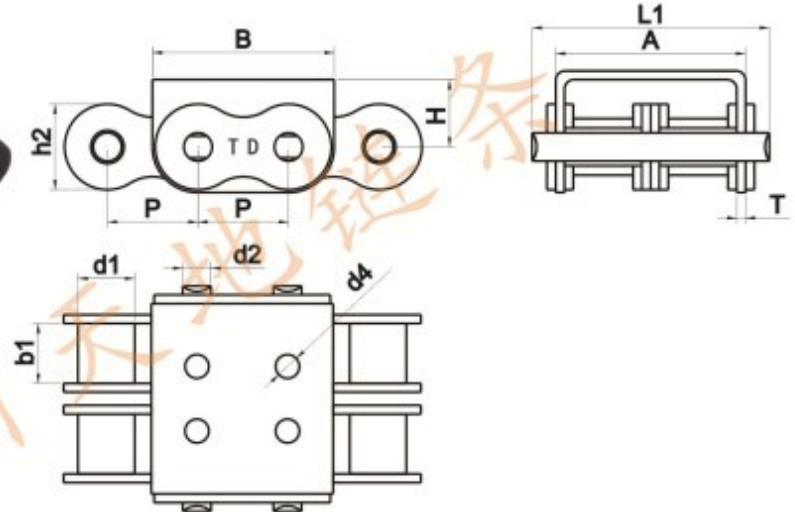

不加外片 B Type  
Without outer plate

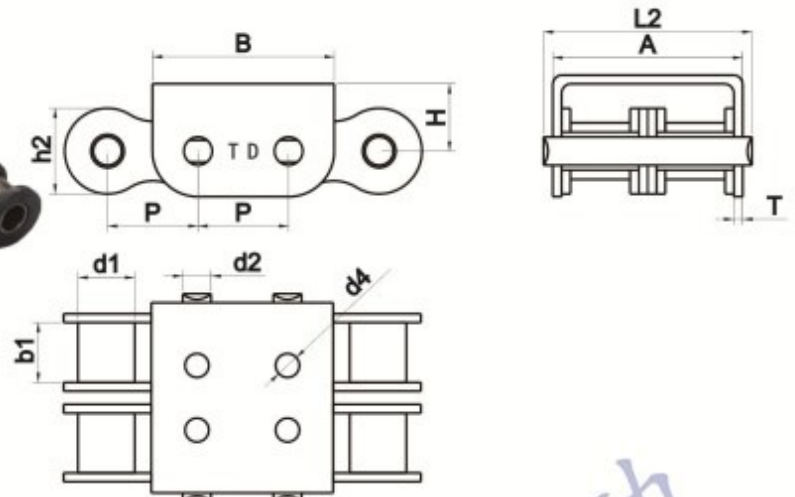

天地型号 Chain No.	节距 Pitch P	滚珠直径 Roller diameter d1 max	内节内宽 Width between inner plates b1 min		销轴直径 Pin diameter d2 max	链片宽度 Plate depth h2 max	销轴长度 Pin length A Type B Type L1 L2 max max		U板尺寸 U plate size A B H d4				形状 Type	U板厚度 U plate thickness t	极限抗拉强度 Ultimate tensile strength Q min	每米重量 Weight per meter q
			mm	mm			mm	mm	mm	mm	mm	mm				
06B-U2	9.525	6.35	5.72	3.28	8	24	27	21.7	17.6	6.4	4	-	1.3			
08A-U2	12.7	7.95	7.85	3.96	12	34.2	31.2	28.4	24.2	8.3	4	-	1.5	32/7273	1.85	
08B-U2	12.7	8.51	7.75	4.45	11.8	34.1	31.2	28.4	24.2	8.3	4	-	1.5	32/7273	1.96	
08B-U2F1	12.7	8.51	7.75	4.45	11.8	34.1	31.2	28.4	24.1	8.3	5.5	-	1.5	32/7273	1.96	
08B-U2F2	12.7	8.51	7.75	4.45	11.8	34.1	31.2	28.4	24.8	8.3	5.5	C	1.5	32/7273	1.96	
08B-U2F3	12.7	8.51	7.75	4.45	11.8	34.1	31.2	28.4	24.8	8.3	5.5	D	1.5	32/7273	1.96	
10A-U2	15.875	10.16	9.4	5.08	15	41.8	37.8	36	30	12.5	5	-	2	42.3/9822	2.6	
10A-U2F1	15.875	10.16	9.4	5.08	15	41.8	37.8	35.5	30	12.5	5	-	1.5	40/9500	2.5	
10A-U2F2	15.875	10.16	9.4	5.08	15	41.8	37.8	36	29.6	12.5	5	D	2	42.3/9822	2.6	
10B-U2	15.875	10.16	9.65	5.08	14.7	39.5	35.9	33.3	30	11.3	5	-	1.5	44.5/10114	2.47	
10B-U2F1	15.875	10.16	9.65	5.08	14.7	39.5	35.9	33.3	30	11.3	-	D	1.5	44.5/10114	2.47	
12A-U2	19.05	11.91	12.57	5.94	16	51	47	44.5	36	13	5	-	1.85	55.3/12136	3.12	
12A-U2F1	19.05	11.91	12.57	5.94	16	51	47	44.5	33.7	26.9	-	-	1.85	55.3/12136		
12A-U2F2	19.05	11.91	12.57	5.94	16	51	47	44.5	36	13	-	D	1.85	55.3/12136	3.12	
12A-U3	19.05	11.91	12.57	5.94	16	65.8	61	57	34	13	-	-	1.85	95.4/21682	4.86	
12B-U2	19.05	12.07	11.68	5.72	16	45.3	42.9	39.1	36	12	5	-	1.85	57.8/13136	3.03	
12B-U2F1	19.05	12.07	11.68	5.72	16	46.6	42.9	39.1	34	12	5	-	1.85	57.8/13136	3.03	
12B-U2F2	19.05	12.07	11.68	5.72	16	45.3	42.9	39.1	33	12	4.2	-	1.85	57.8/13136	3.03	
12B-U2F3	19.05	12.07	11.68	5.72	16	45.3	42.9	39.1	36	12	-	D	1.85	57.8/13136	3.03	
16A-U2	25.4	15.88	15.75	7.92	24	66.7	61.2	57.2	46	16	7	-	2.42	115/30124	6.1	
16B-U2	25.4	15.88	17.02	8.28	21	71.7	67	60.93	49	16.2	6	-	1.5	106/26094	6.97	
20A-U2	31.75	19.05	18.9	9.53	30	85	88	71	58	22.5	6.5	-	3.8			
24A-U2	38.1	22.23	25.22	11.1	35.7	104	94.4	88	75.2	29	-	-	4		19	
24B-U2	38.1	25.4	25.4	14.63	33.2	111.1	114	95.7	71.5	46.1	-	-	5			

材质: 碳钢、不锈钢  
Material: carbon steel, stainless steel

平板与链条 固定方式有：  
焊接 (Type A) 铆钉 (Type B, 平板需带孔)

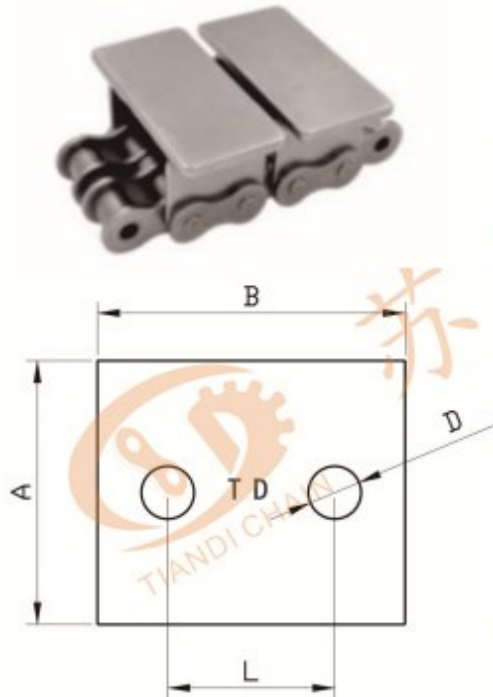

天地型号 Chain No.	附板尺寸 attachment size					固定方式 Fixed mode Type
	A	B	D	L	T	
08B-U1-PB-F1	8.4	21.25	3.7	12.7	4	B
12B-U2-PB-F1	30	35	2-6	19.05	3	B
12B-U2-PB-F2	36	39	2-6.5	20	4	B
12B-U2-PB-F3	35	76	4-5	19.05	5	B
12B-U2-PB-F4	35	70	-	-	4	A
12A-2-K1-PB-F2	27	35	2-6	23	2.4	B
12A-2-K1-PB-F3	32	40	4-6	24	2.4	B
12A-2-K1-PB-F4	27	45	2-6.8	25	2.4	B
12A-2-K1-PB-F5	27	48	2-6.1	23	2.4	B
12A-2-K1-PB-F6	24	84	2-6.5	61	2.4	B
12A-G2-PB-F7	50	55	7	-	2.4	B
12A-2-K1-PB-F8	33	85.4	5	61	2.4	B
16A-2-K1-PB-F1	24	72.8	8	53.8	3	B
16A-2-K1-PB-F2	14.6	76.8	4-5	19.05	3	B
C2060-PB	28	50	-	-	5	A

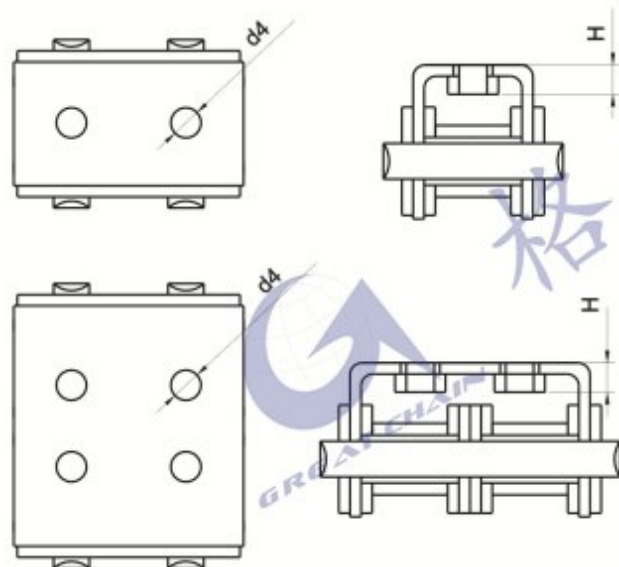

天地型号 Chain No.	螺母尺寸 Nut size	
	d4 mm	H mm
08A-U1-GS	M3/M4	5/6
08B-U1	M3/M4	5/6
10A-U1	M4/M5	6/7
10B-U1	M4/M5	6/7
12A-U1	M4/M5	6/7
12B-U1	M4/M5	6/7
16A-U1	M5/M6	7/8
16B-U1	M5/M6	7/8
20A-U1	M6/M8	8
20B-U1	M6/M8	8
24A-U1	M6/M8	8
24B-U1	M6/M8	8
08A-U2	M3/M4	5/6
08B-U2	M3/M4	5/6
10A-U2	M4/M5	6/7
10B-U2	M4/M5	6/7
12A-U2	M4/M5	6/7
12B-U2	M4/M5	6/7
16A-U2	M5/M6	7/8
16B-U2	M5/M6	7/8
20A-U2	M6/M8	8



# 非标平板链

Roller chain with special flat attachments



04C-U1-F2

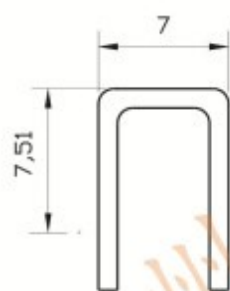
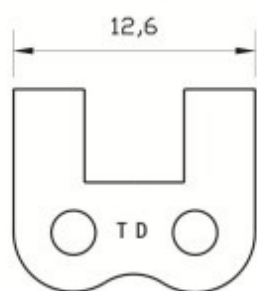

A2040-U1

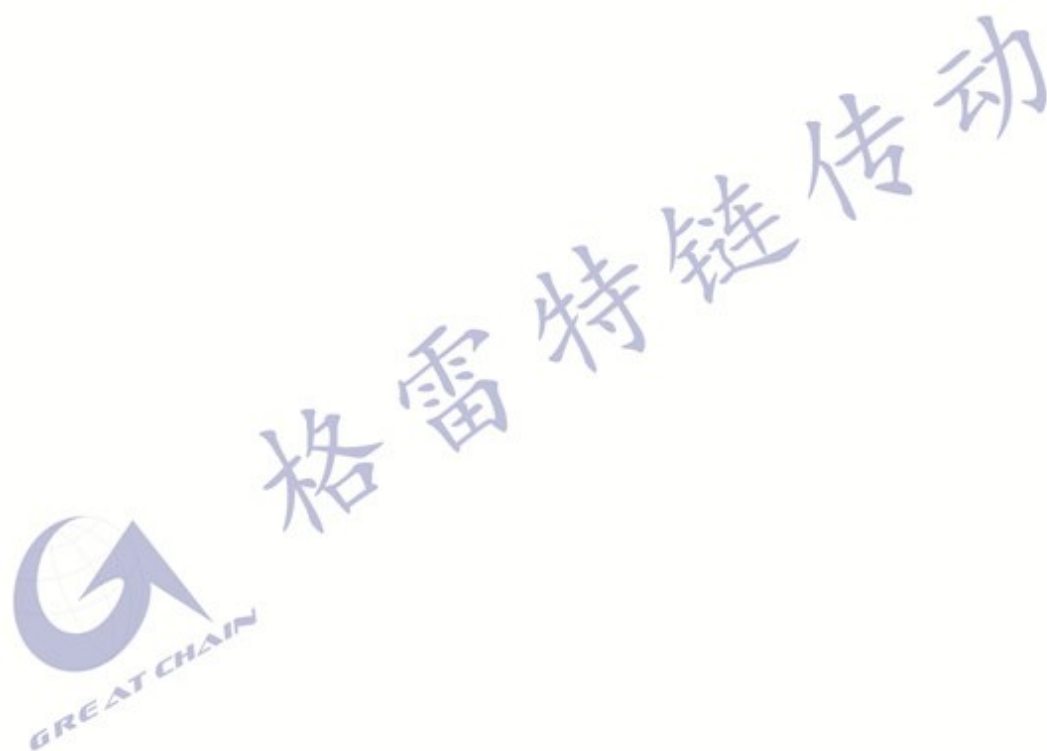
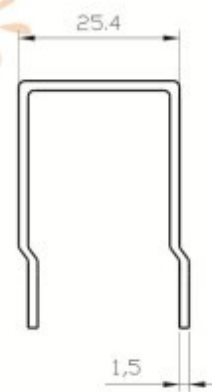
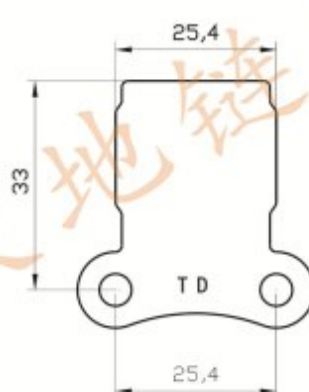

# 橡胶链

## Roller chain with vulcanised elastomer profiles

加外片 A Type  
with outer plate

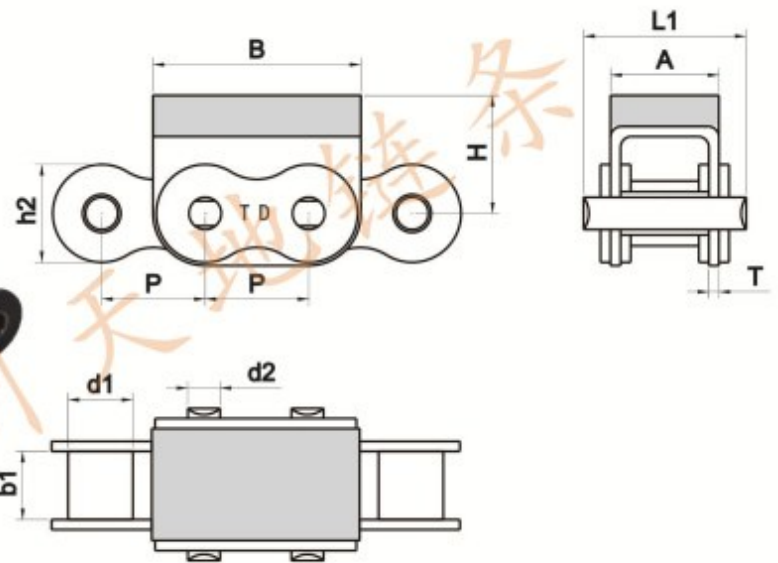

不加外片 B Type  
without outer plate

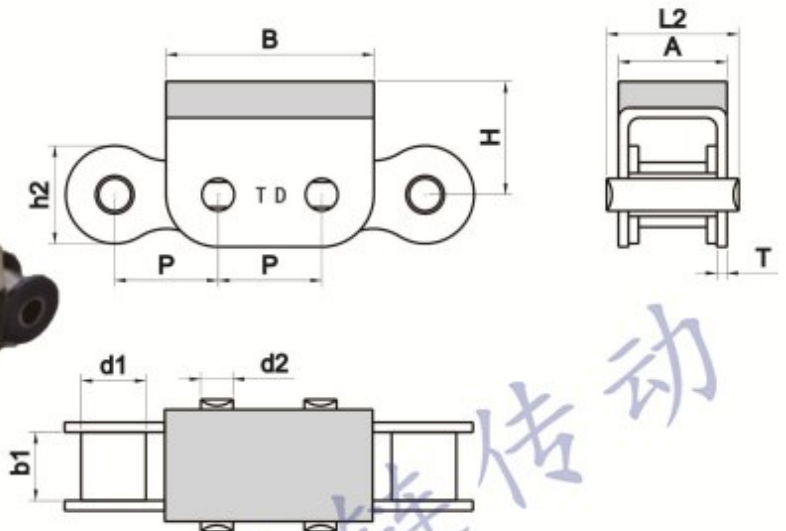

天地型号 Chain No.	节距 Pitch P	滚珠直径 Roller diameter d1	内节内宽 Width between inner plates b1		销轴直径 Pin diameter d2	链片宽度 Plate depth h2	销轴长度 Pin length L1 L2		橡胶块尺寸 Plate and attachment size A B H			U板厚度 U plate thickness T	极限抗拉强度 Ultimate tensile strength Q min	每米重量 Weight per meter q
			max	min			max	max	max	max	max			
04C-G1	6.35	3.3	3.18	2.31	6	10.6	8.9	7	11.5	14.1	1	3.5/795	0.38	
06B-G1	9.525	6.35	5.72	3.28	8.2	16.1	13.2	11.4	17.3	7.5	1.3	9/2045	0.8	
08B-G1	12.7	8.51	7.75	4.45	11.8	19.4	16.4	14.6	24.2	12.3	1.5	18/4091	1.19	
08B-G1F80	12.7	8.51	7.75	4.45	11.8	19.4	16.4	14.6	24.2	13.8	1.5	18/4091	1.2	
10A-G1	15.875	10.16	9.4	5.08	15	24	21	17.5	30	17	1.5	21.8/4953	1.7	
10B-G1	15.875	10.16	9.65	5.08	14.7	23	19.5	16.8	30	17	1.5	19/4318	1.62	
12A-G1	19.05	11.91	12.57	5.94	18	32	27.2	21.4	36	17	1.85	31.8/7153	2.55	
12B-G1	19.05	12.07	11.68	5.72	16	26	22.3	19.6	36	17	1.85	57.8/13136	2.01	
16A-G1	25.4	15.88	15.75	7.92	24	37.2	30.8	27.5	46	20	2.42	42/9545	3.97	
16B-G1F12	25.4	15.88	17.02	8.28	21	41	34.8	29.05	49	20	1.5	58/13047	3.83	
20A-G1	31.75	19.05	18.9	9.53	30	46.8	40.8	34	57.6	28	3.1	86.7/19503	6.15	
20B-G1	31.75	19.05	19.56	10.19	26.4	48	41	36	57	27	3.5	85/19318	6.19	
24A-G1	38.1	22.23	25.22	11.1	35.7	58.3	50.3	46	75.2	35	4	127/28864	10.7	
24B-G1	38.1	25.4	25.4	14.63	33.2	61.6	52	47	72.6	34	4.5	160/36363	11.25	
32A-G1	50.8	28.58	31.55	14.27	47.8	76.2	-	58.2	100.4	59	6.4	226.8/51545		



# 橡胶链

## Roller chain with vulcanised elastomer profiles



加外片 A Type  
with outer plate

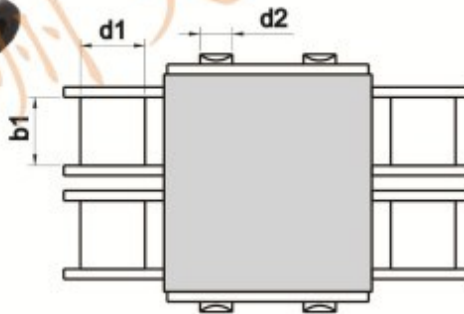
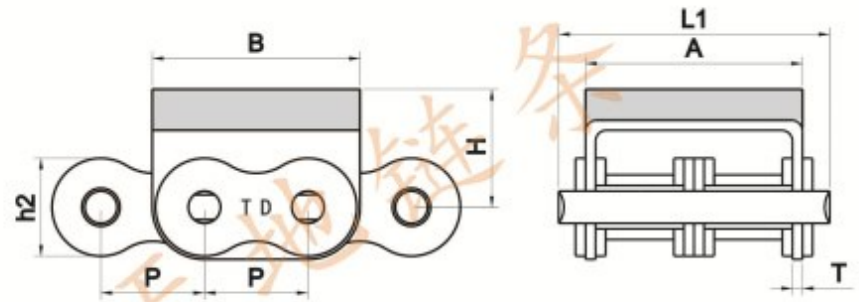

不加外片 B Type  
without outer plate

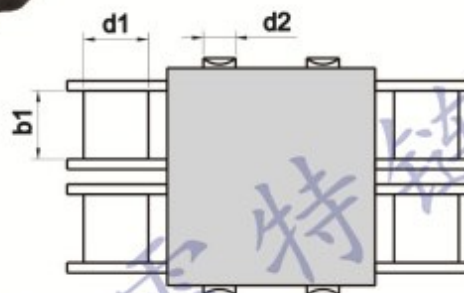
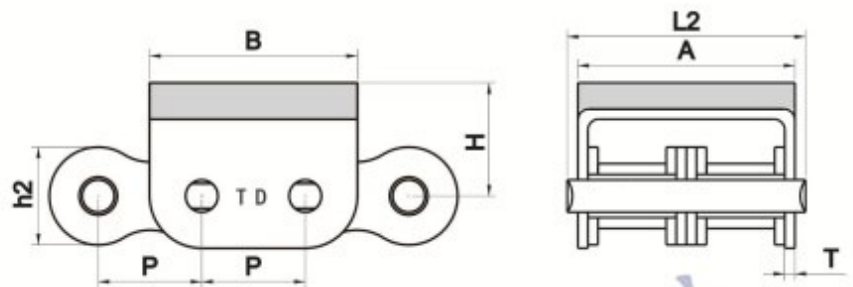

天地型号 Chain No.	节距 Pitch p	滚珠直径 Roller diameter d1	内节内宽 Width between inner plates b1		销轴直径 Pin diameter d2	链片宽度 Plate depth h2		销轴长度 Pin length			橡胶块尺寸 Plate and attachment size			U板厚度 U plate thickness T	极限抗拉强度 Ultimate tensile strength Q min	每米重量 Weight per meter q
			max	min		max	max	A Type L1 max	B Type L2 max	A	B	H				
08B-G2	12.7	8.51	7.75	4.45	11.8	34	31.2	28.4	24.2	12.3	1.5	32/7273	2.07			
10A-G2	15.875	10.16	9.4	5.08	15	41.8	37.8	36	30	17	2	42.3/9822	2.72			
10B-G2	15.875	10.16	9.65	5.08	14.7	38.4	35.4	33.3	30	16	1.5	44.5/10114	2.56			
12A-G2	19.05	11.91	12.57	5.94	16	51	46.1	44.5	36	17	1.85	55.3/12136	3.31			
12B-G2	19.05	12.07	11.68	5.72	16	46.6	42.9	39.1	36	16	1.85	57.8/13136	3.21			
12B-G2F81	19.05	12.07	11.68	5.72	16	46.6	42.9	39.1	36	28.4	1.85	57.8/13136				
16A-G2	25.4	15.88	15.75	7.92	24	66.7	60.2	57.2	46	20	2.42	115/30124	7.27			
16B-G2	25.4	15.88	17.02	8.28	21	73.2	67	60.93	49	22	1.5	106/26094	7.35			
20A-G2	31.75	19.05	18.9	9.53	30	85	88	71.8	58	28	3.8					
C20B-G2	31.75	19.05	29.56	10.19	26.4	85	78	73	58, 15	27	3.5	170/38217	10.4			

# 橡胶链

## Roller chain with vulcanised elastomer profiles

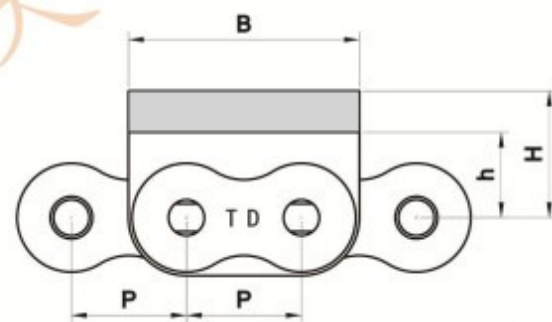
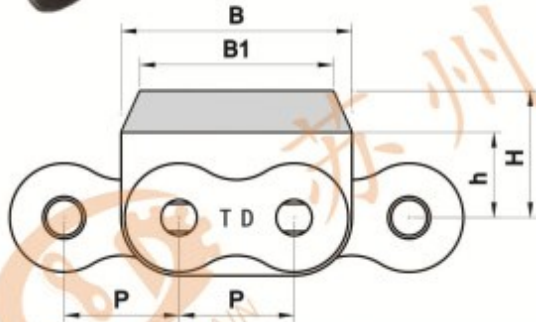
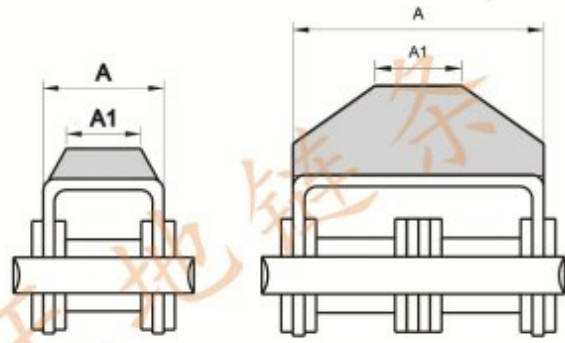

天地型号 Chain No.	节距 Pitch	橡胶块尺寸 Plate and attachment size					
		P	A	A1	B	B1	h
	mm	mm	mm	mm	mm	mm	mm
08B-G1F12	12.7	14.6	11.66	24.2	21.45	8.3	24
08B-G1F14	12.7	14.6	12	24.2	21.48	8.3	16
08B-G1F17	12.7	14.6	6.86	24.2	-	8.3	20.2
10A-G1F6	15.87	16.8	-	30	-	11.3	14
10B-G1F5	15.875	16.8	13.5	30	-	11.3	25.3
10B-G2F5	15.875	33.3	29.4	36	-	11.3	25.3
12A-G1F1	19.05	26	17	36	-	13	16
12A-G1F12	19.05	39.1	-	36	-	13	21
12B-G1F11	19.05	19.6	13.5	36	-	13	17
12B-G1F14	19.05	38.2	37.4	35	34.2	11.5	16
12A-G2F12	19.05	39.1	-	36	-	13	21
12B-G2F5	19.05	39.1	-	36	-	12	28
12B-G2F10	19.05	39.1	34	36	-	12	28
12B-G2F12	19.05	39.1	34.4	36	32.83	12	21
12B-G2F14	19.05	39.1	34	36	34	12	34
C12B-G2F22	19.05	39.1	37	36	30	12	28
16A-G1F1	25.4	27.5	-	46	-	16	21.4
16A-G1F3	25.4	27.5	22	49	47.1	16	21.4
16A-G1F4	25.4	27.5	25.6	49.2	-	16	20
16B-G1F12	25.4	29.05	24.5	49	-	15.4	21.4
16B-G1F18	25.4	29.05	-	49	-	15.4	32
20A-G1	31.75	34	30	57.65	55.5	22	28
C20A-G1	31.75	34	30	61.75	59.63	22	28
20B-G1F1	31.75	36	-	57	-	21	35
C20B-G1	31.75	36	30	57	54.88	21	27
C20B-G2	31.75	73	60	58.15	56	21	27
24A-G1F1	38.1	55.5	50.4	70	66.2	24.5	46.5
C24B-G1	38.1	47	44	72.6	-	28	34



# 橡胶链

## Roller chain with vulcanised elastomer profiles

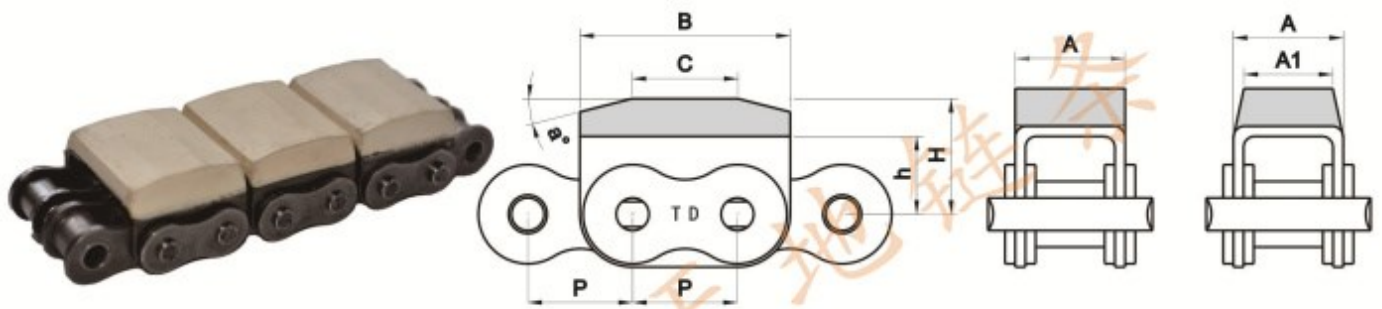

天地型号	节距 Pitch	橡胶块尺寸 Plate and attachment size						
Chain No.	P	A	A1	B	C	a	h	H
	mm	mm	mm	mm	mm	mm	mm	mm
08B-G1F14	12.7	14.6	-	24.2			8.3	16
08B-G2F1	12.7	28.4	25.4	24.2	9	9	8.3	12
08B-G2F15	12.7	28.4	25.4	24.2	9	15	8.3	12.8
08B-G2F22	12.7	28.4	25.4	24.2			8.3	12
C16AG1F7	25.4	27.5	26.4	49	25	15	16	21.4
16B-G1	25.4	29.05	-	49	25	15	15.4	21.4
16B-G1F11	25.4	29.05	-	49	41	15	15.4	21.4
C16B-G2	25.4	60.93	-	49	25	15	15.4	21.4
20B-G1F2	31.75	36	-	57			21	35
24B-G1F1	38.1	47	39.6	72.6	32.6	11	28	34
24B-G1F7	38.1	47	44	72.6	35	12	28	34

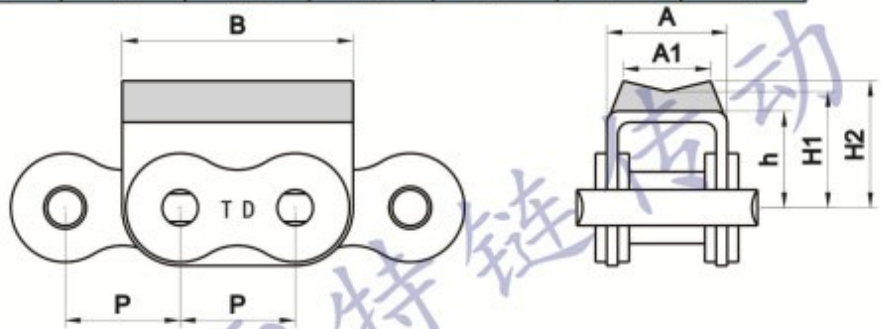

天地型号	节距 Pitch	橡胶块尺寸 Plate and attachment size					
Chain No.	P	A	A1	B	h	H1	H2
	mm	mm	mm	mm	mm	mm	mm
08B-G1F9	12.7	14.6	11	24.2	8.3	10.8	12.3
08B-G2F11	12.7	28.4	26.6	24.2	8.3	18.3	20.1
12B-G1F1	19.05	19.6	14.5	36	13	16	18
12B-G1F13	19.05	19.6	14.2	36	13	19.1	21
12B-G1F80	19.05	15.4	12.8	33.8	13	26	28
12B-G2F4	19.05	39.1	35	36	12	24.5	27.5
12B-G2F13	19.05	39.1	24	36	12	24.5	27.5
12B-G2F80	19.05	37	16	35	12	28	29.6

# 橡胶链

## Roller chain with vulcanised elastomer profiles

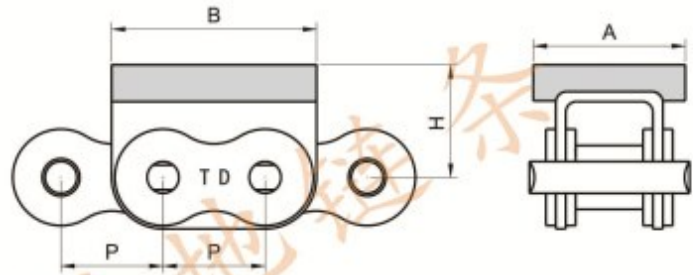

天地型号	节距 Pitch	橡胶块尺寸 Plate and attachment size		
Chain No.	P	A	B	H
	mm	mm	mm	mm
08B-G1F1	12.7	18	24.2	12.3
10B-G1F2	15.875	25	30	14
10B-G1F3	15.875	20	30	18
10B-G1F4	15.875	18.6	30	11.4

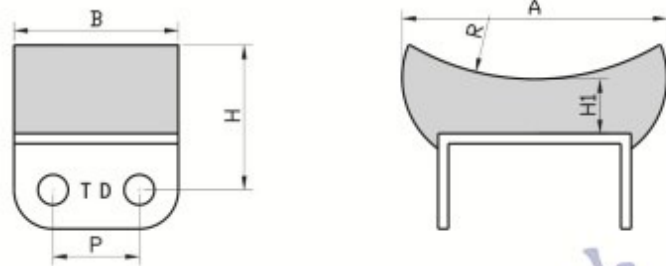

天地型号	节距 Pitch	橡胶块尺寸 Plate and attachment size				
Chain No.	P	A	B	H	H1	R
	mm	mm	mm	mm	mm	mm
08B-G2F16	12.7	44	24.2	26.3	8	27
08B-G2F17	12.7	39	24.2	21.3	8	36

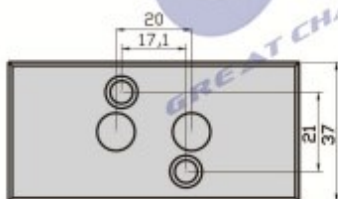
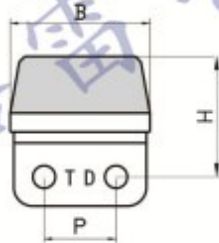
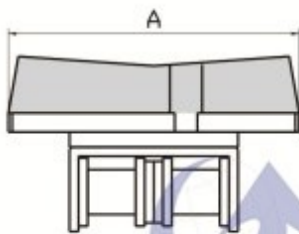

天地型号	节距 Pitch	橡胶块尺寸 Plate and attachment size		
Chain No.	P	A	B	H
	mm	mm	mm	mm
12B-G2F3	19.05	77	37	36
12B-G2F8	19.05	101	37	36



# 橡胶链

## Roller chain with vulcanised elastomer profiles



05B-G1

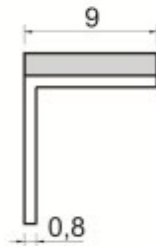
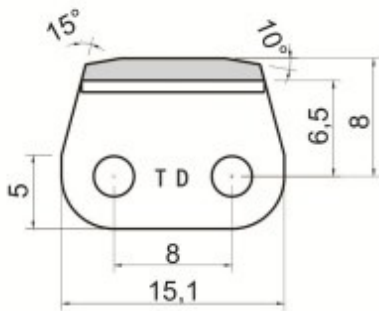

06CWSA2-G1F3

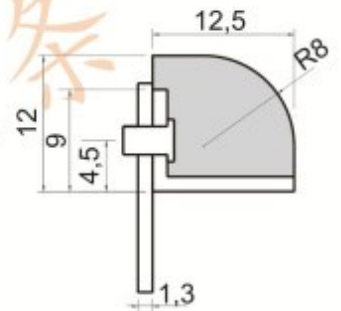
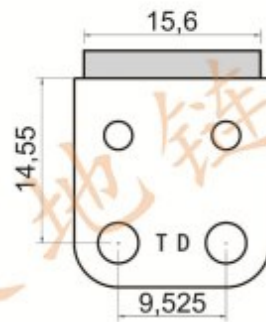

06B-G1 F9

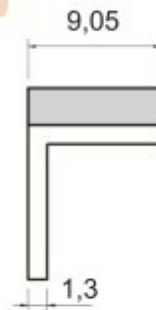
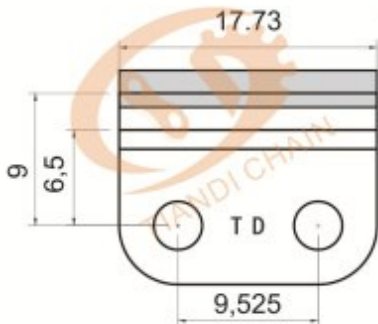

08B-G1F4

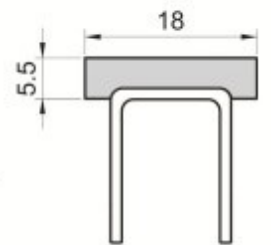
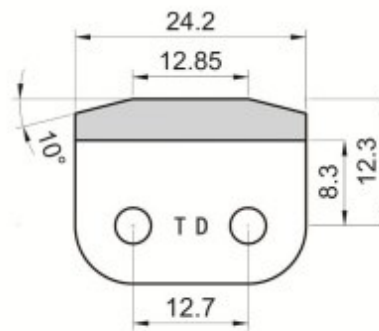

08B-G1F6

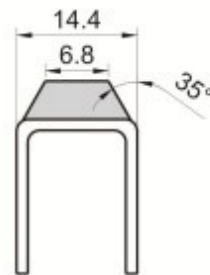
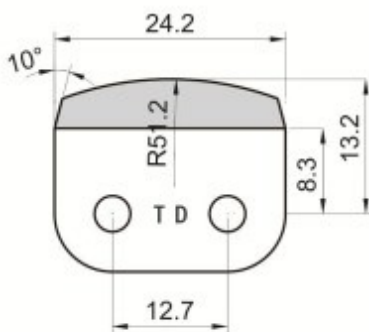

08B-G1F13

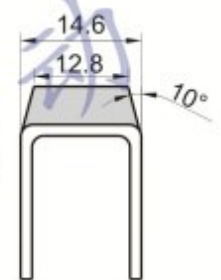
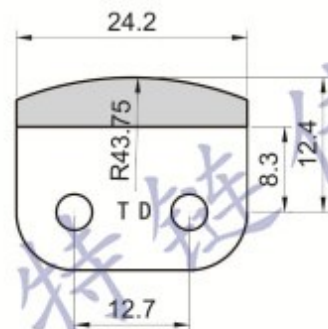

08B-G1F15

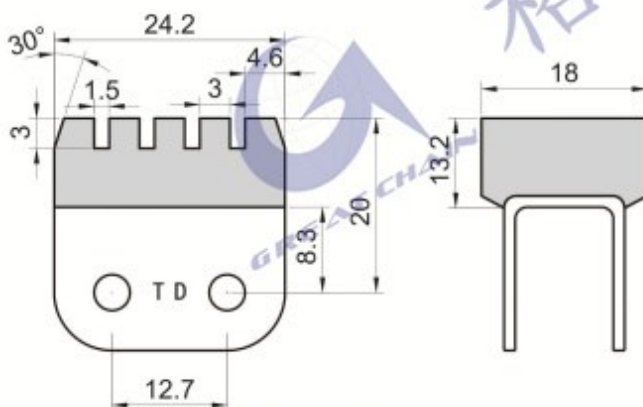

08B-G1F16

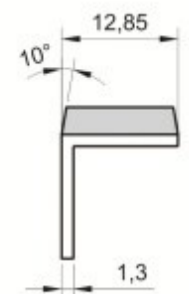
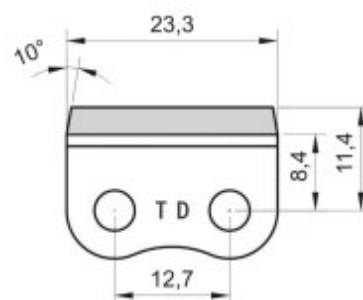

08B-G2F2

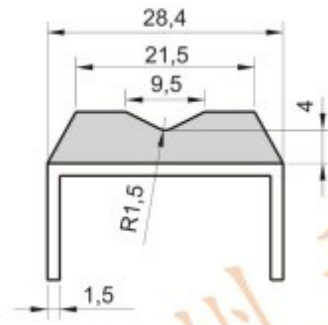
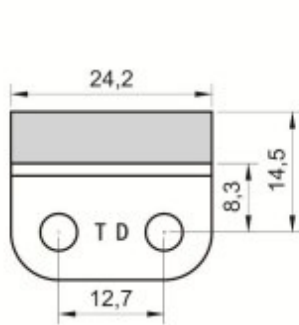

08B-G2F5

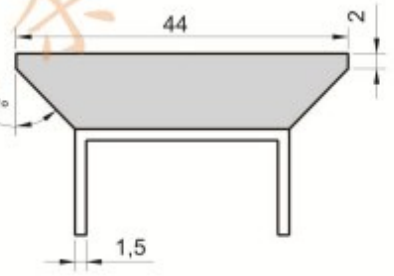
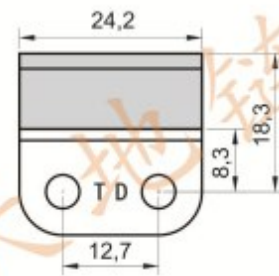

08B-G2F7

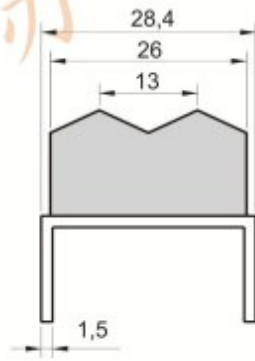
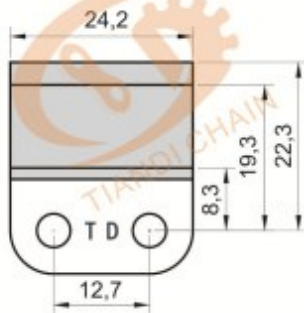

08B-G2F8

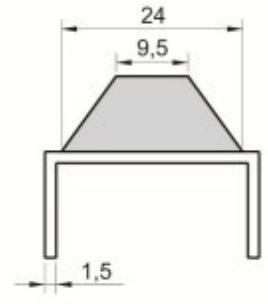
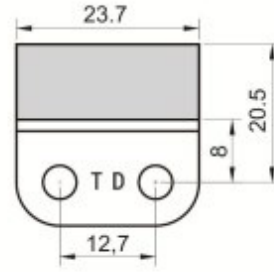

08B-G2F10

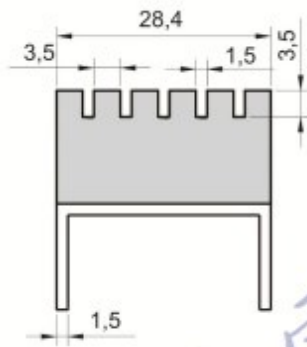
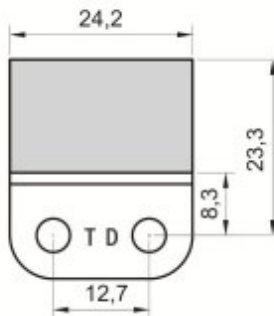

08B-G2F13

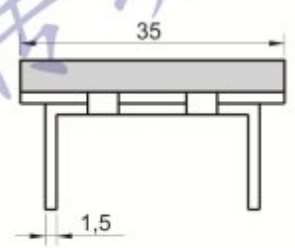
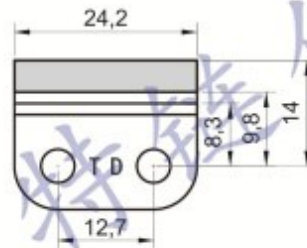

08B-G2F14

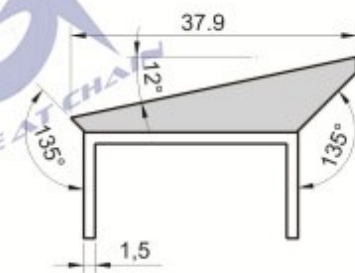
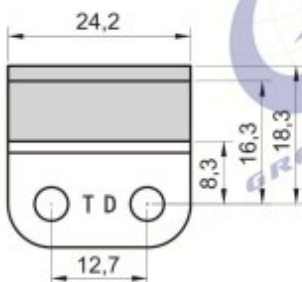

08B-G2F18

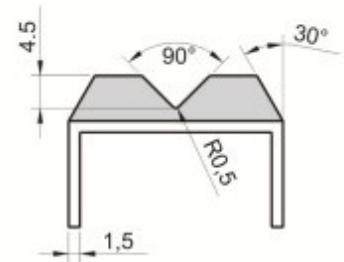
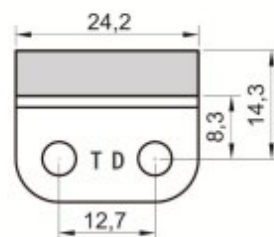



# 橡胶链

## Roller chain with vulcanised elastomer profiles



08B-G2F45

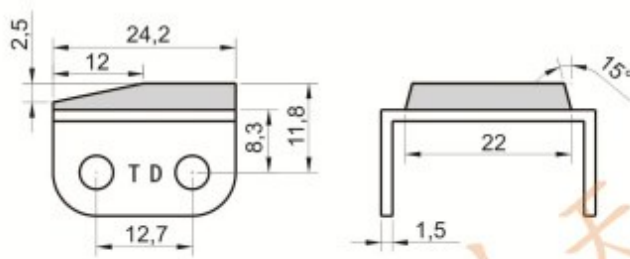

08B-WK2 F4

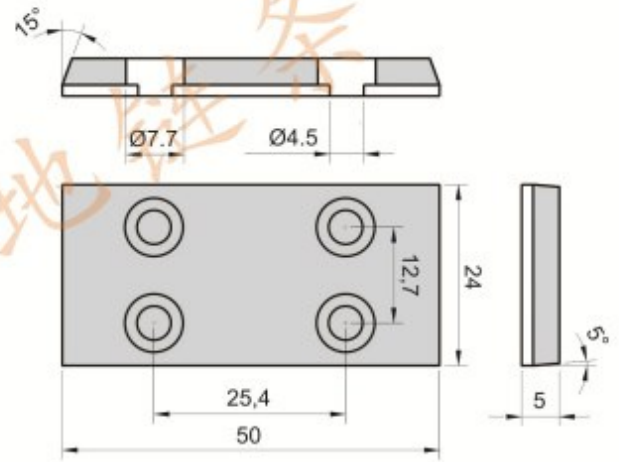

08B-G2F80

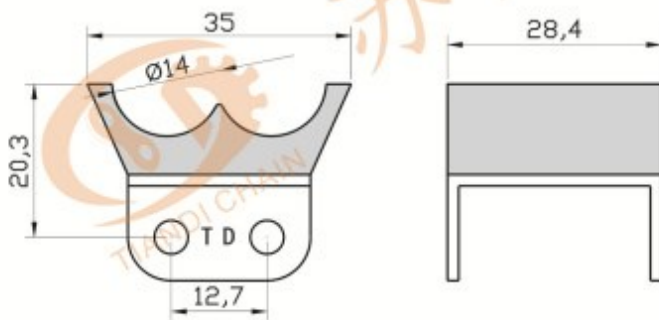

10A-G2F1

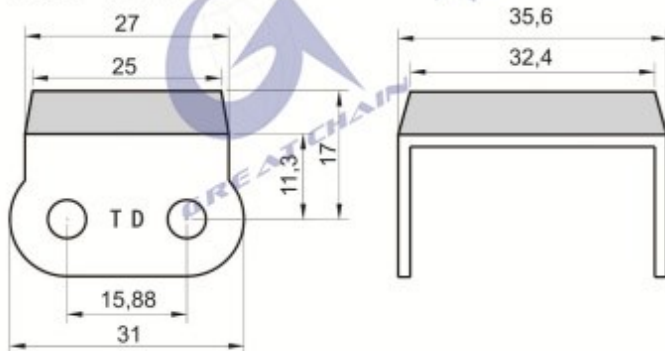

10B-G2F6

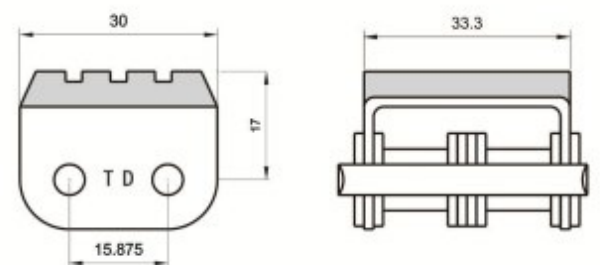

### 12A-G1F1 A1

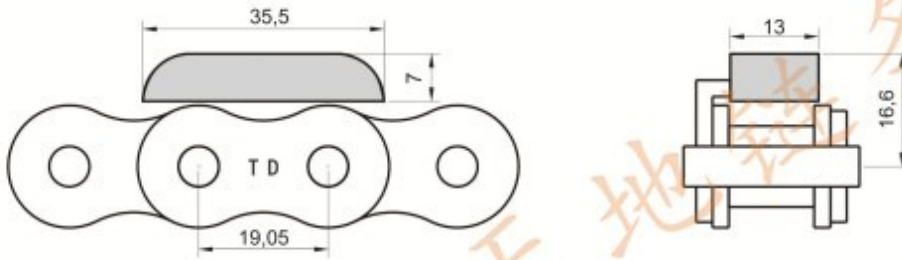

### 12A-G2F15-1



### 12A-G2F15-2

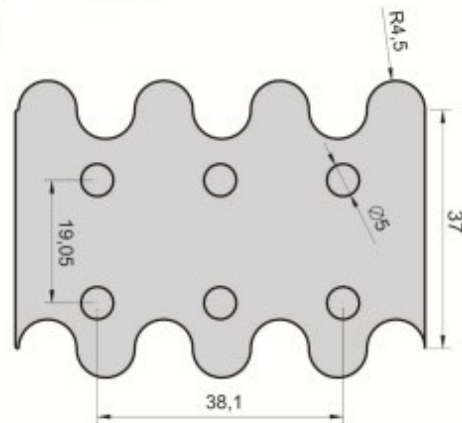
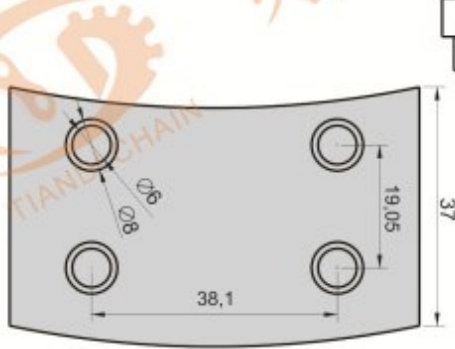

### 12A-G1 F80

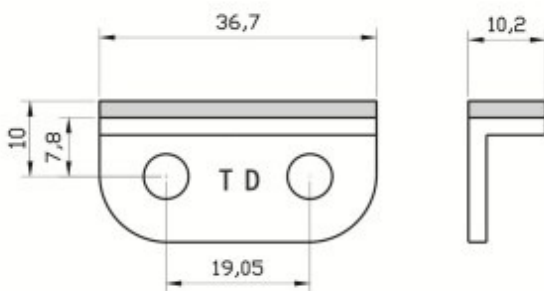

### 12A-G2 F81

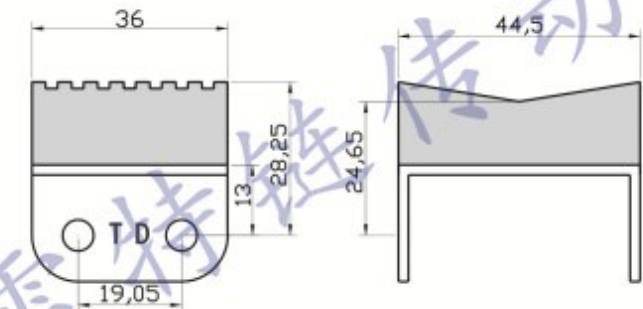

### 12A-G1 F82

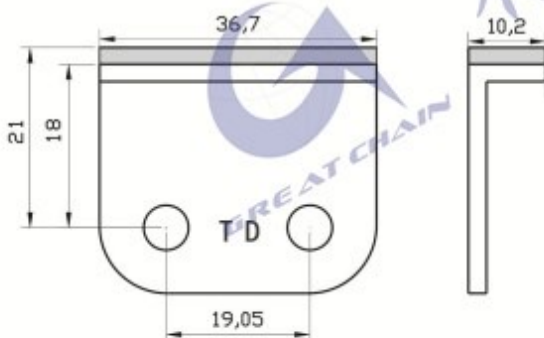



# 橡胶链

## Roller chain with vulcanised elastomer profiles



12A-2 WK2-G2F82

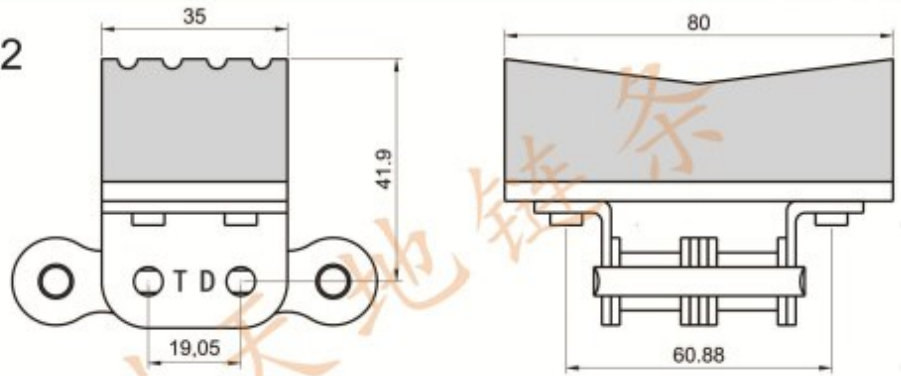

12A-G2 K183

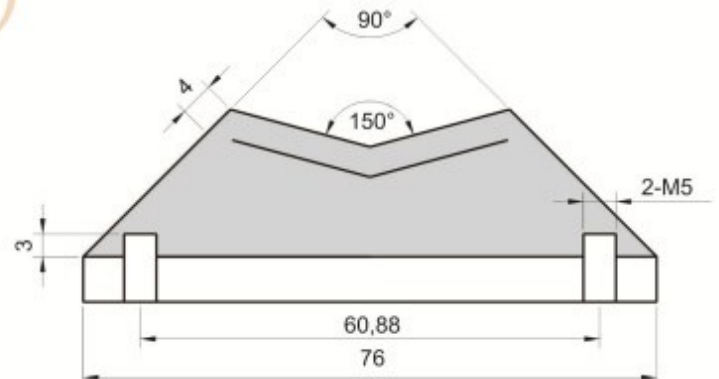
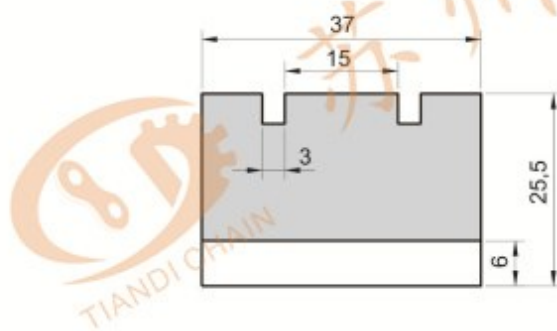

12A-G2 WK1F84

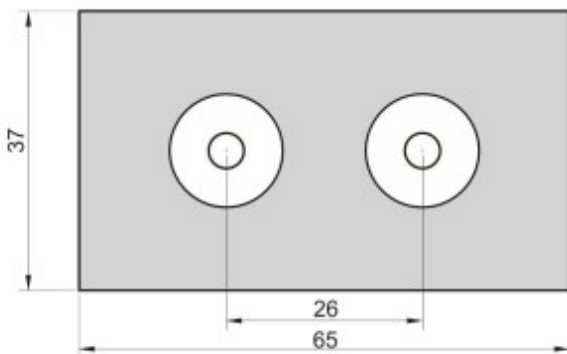

12A-G2 F85

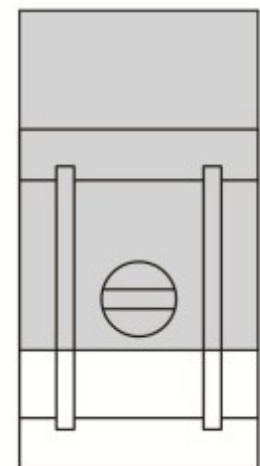
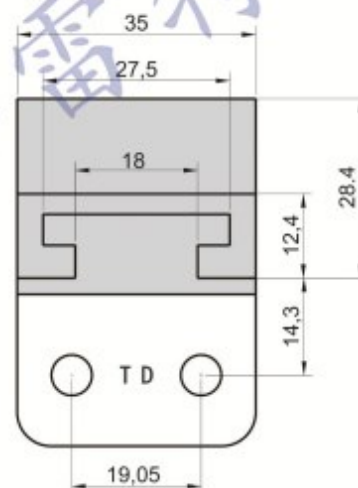
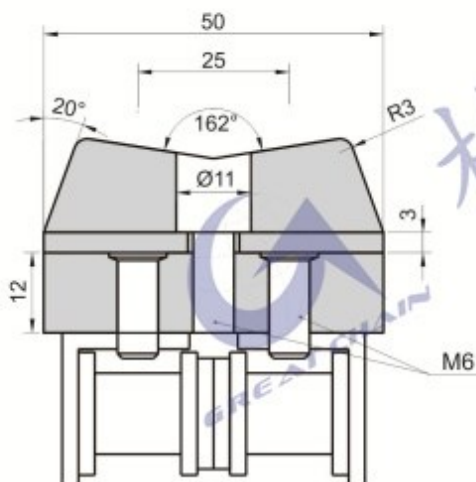



天地链条  
TD CHAIN

# 橡胶链

## Roller chain with vulcanised elastomer profiles

### 12B-G1F2

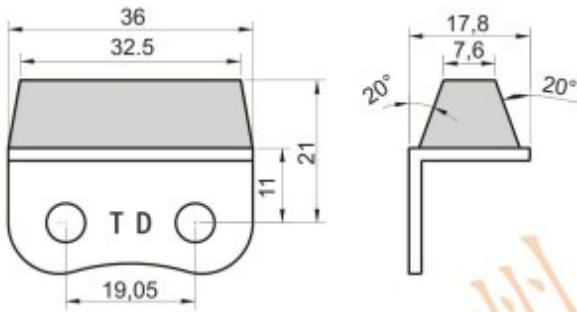

### 12B-G1F9

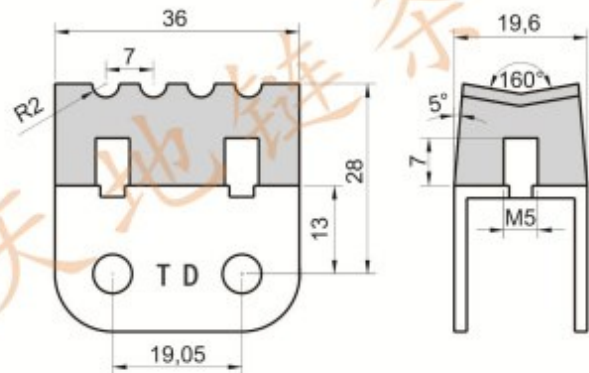

### 12B-G1F80

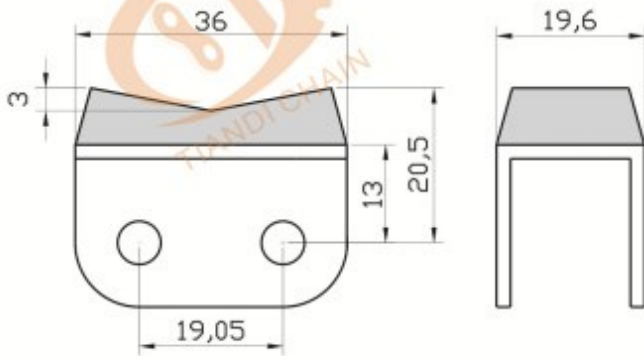

### 12B-G1F81

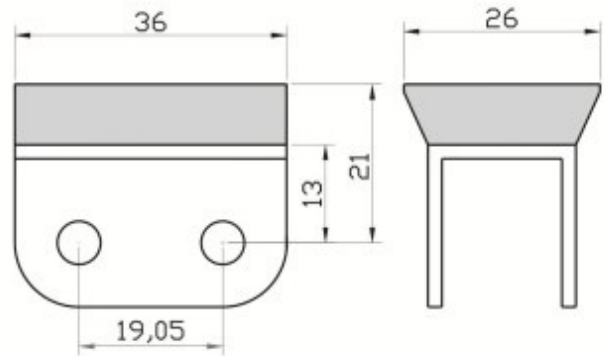

### 12B-G2F5

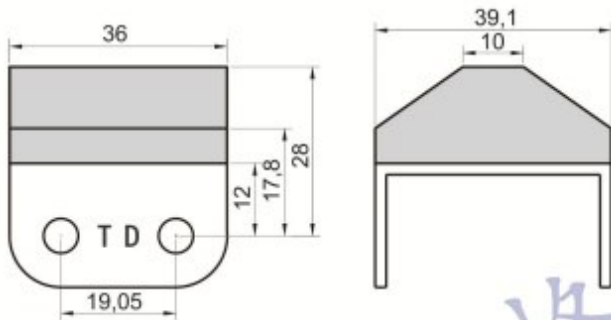

### 12B-G2F6

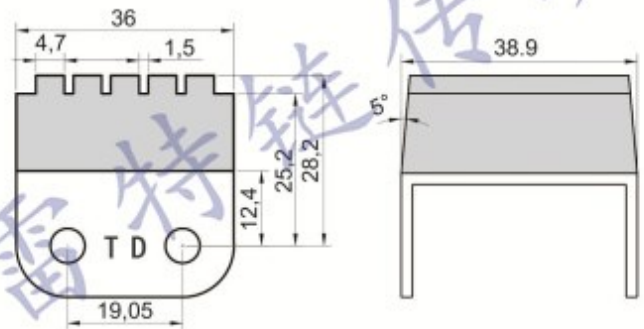

### 12B-G2 F35

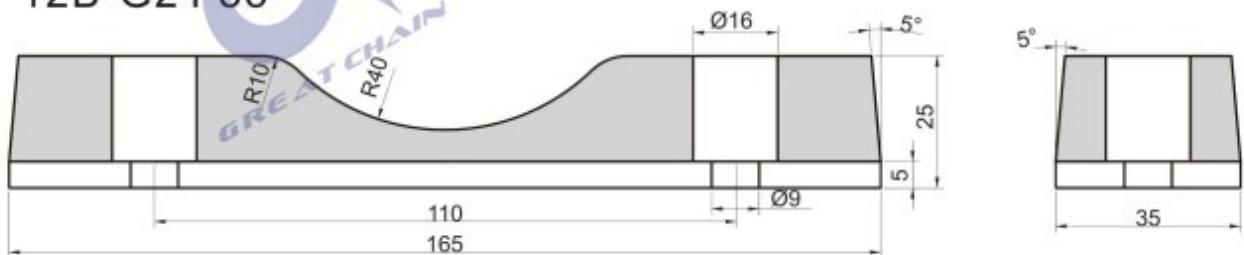



# 橡胶链

## Roller chain with vulcanised elastomer profiles



16A-G1F1

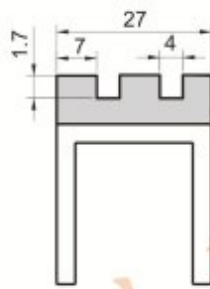
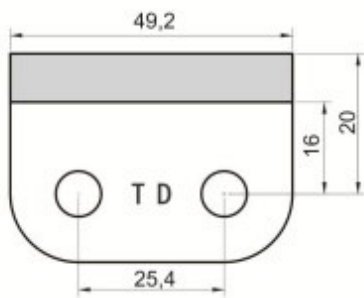

16A-G1F3

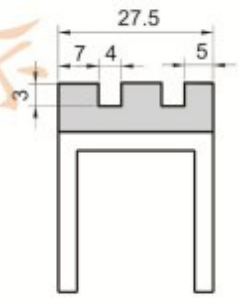
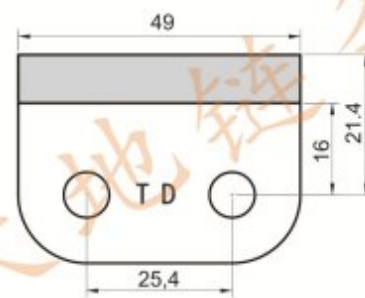

16A-G1F80

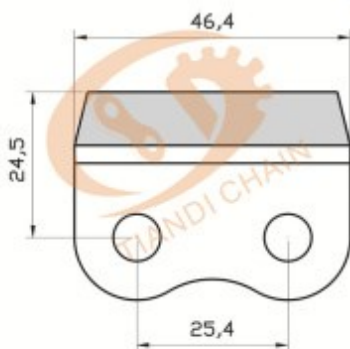

16B-G1F7外片

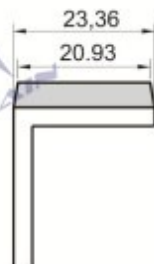
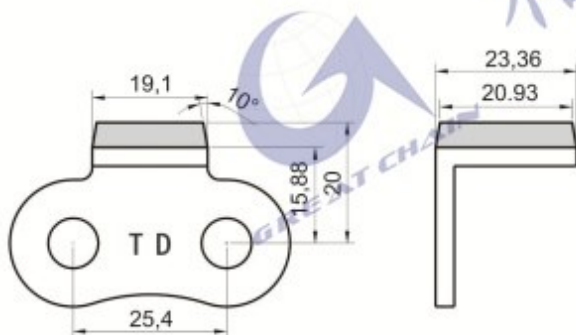

16B-G1F7内片

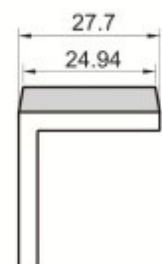
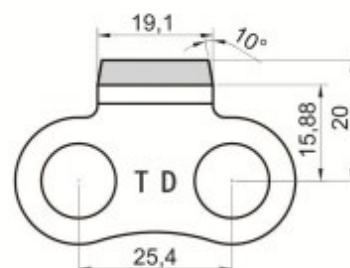

### 16B K1F34

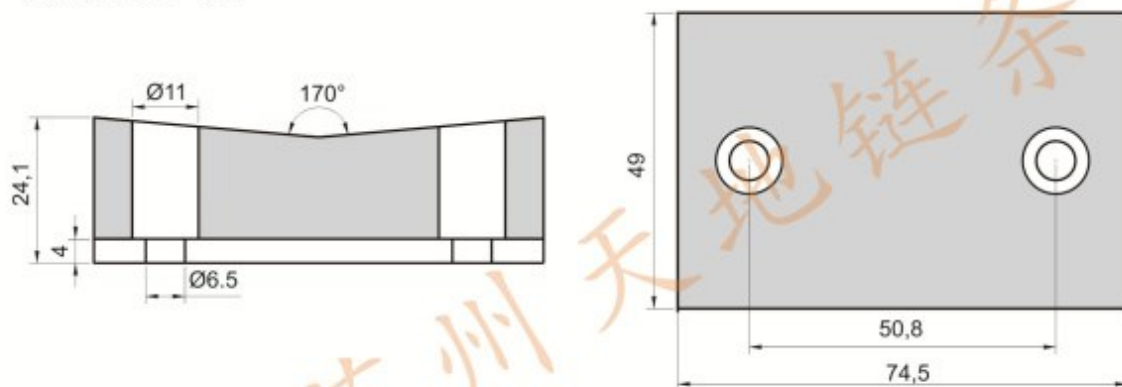

### 16B-G1F8

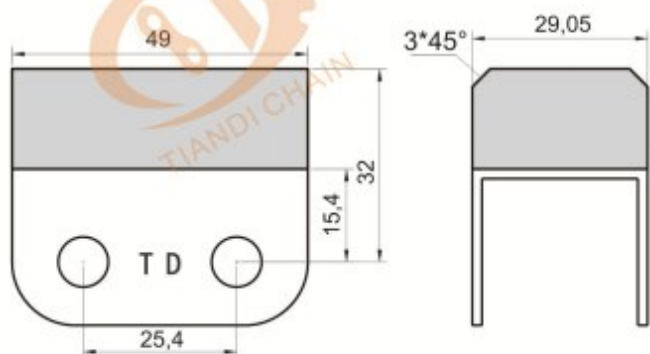

### 20B-G1F2

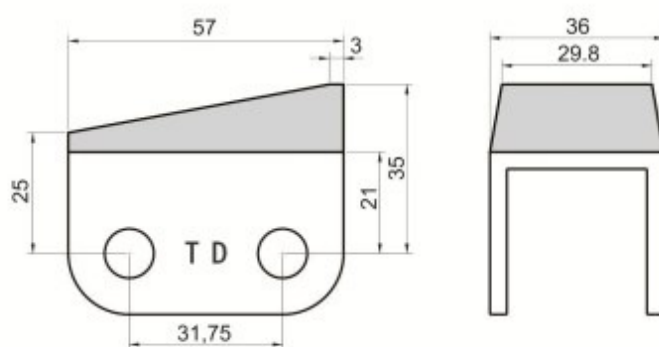



# 橡胶链

## Roller chain with vulcanised elastomer profiles



KG-F1

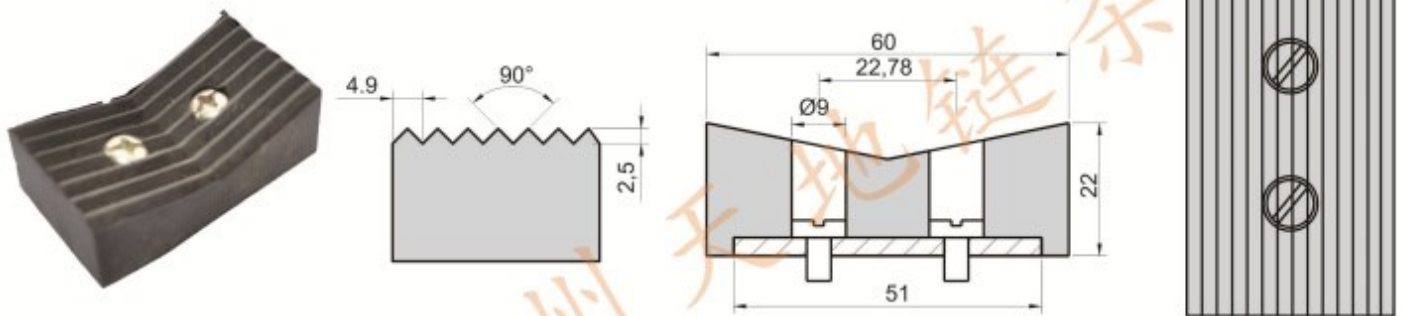

12A-2K1 KG-F2

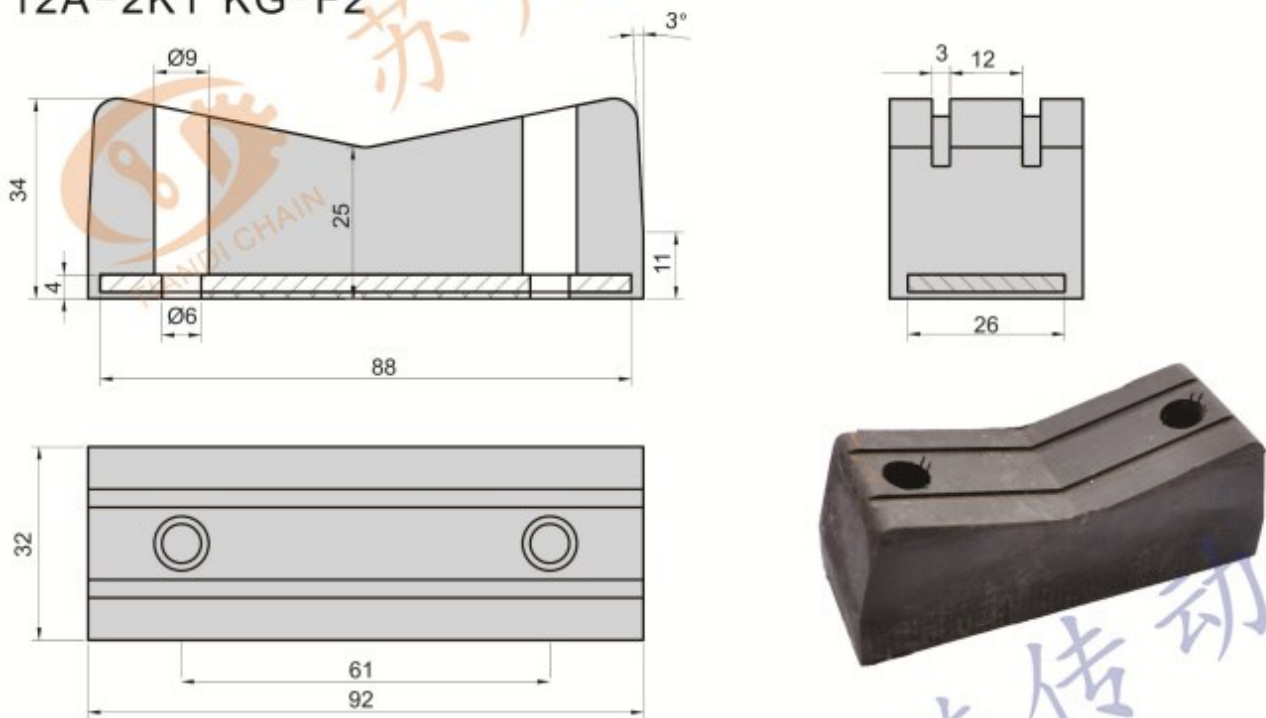

12A-2K1内弯 KG-F3

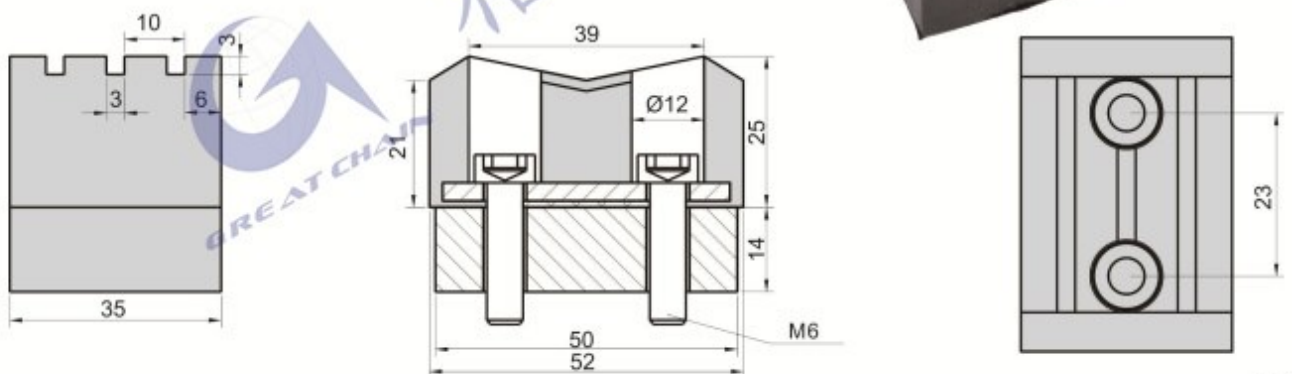



天地链条  
TD CHAIN

# 橡胶链

## Roller chain with vulcanised elastomer profiles

### KG-F4

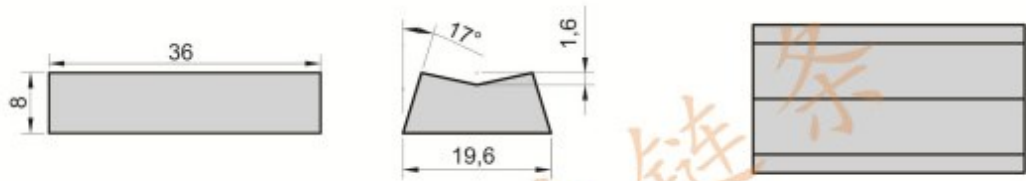

### KG-F5

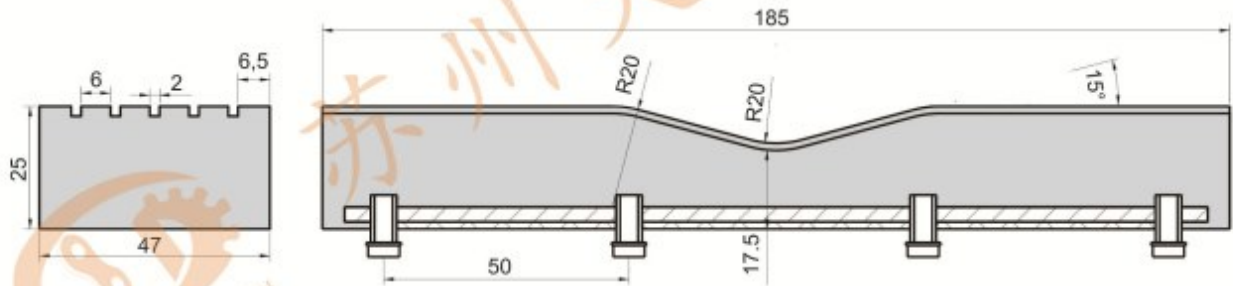

### KG-F6

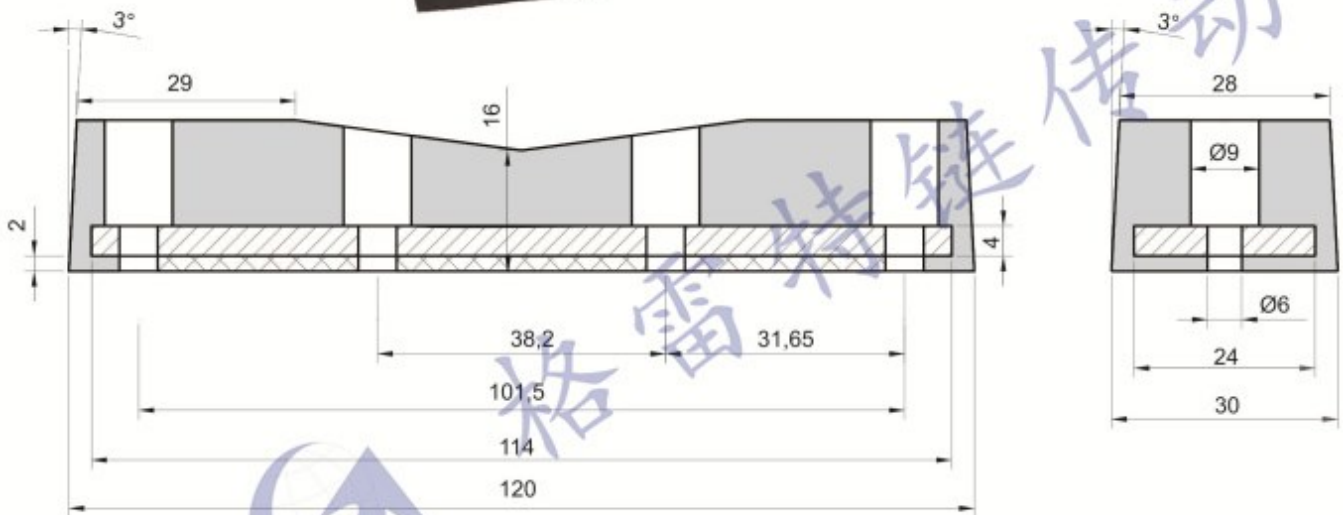

# 橡胶链

## Roller chain with vulcanised elastomer profiles



### 12B-2 K1 KG-F1

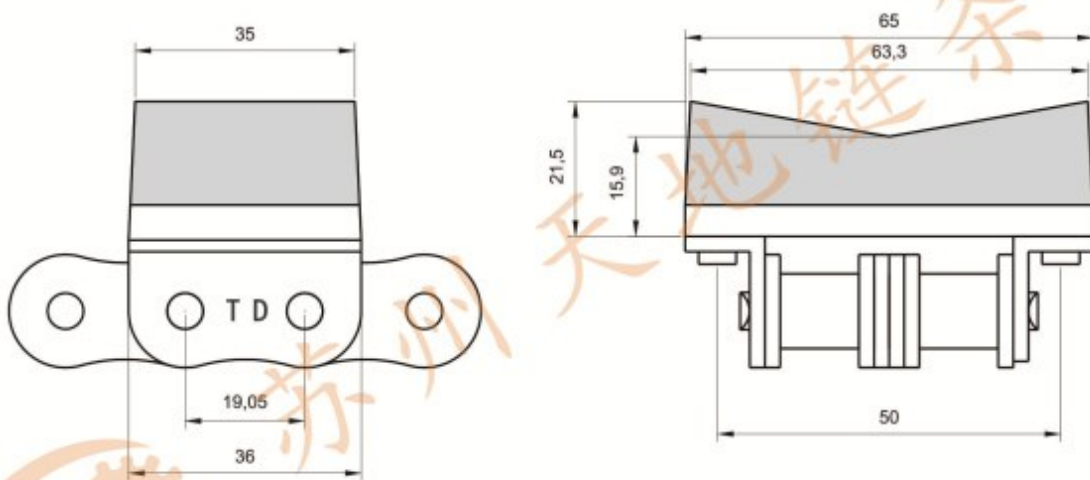

### 16B-2 K1 KG-F1

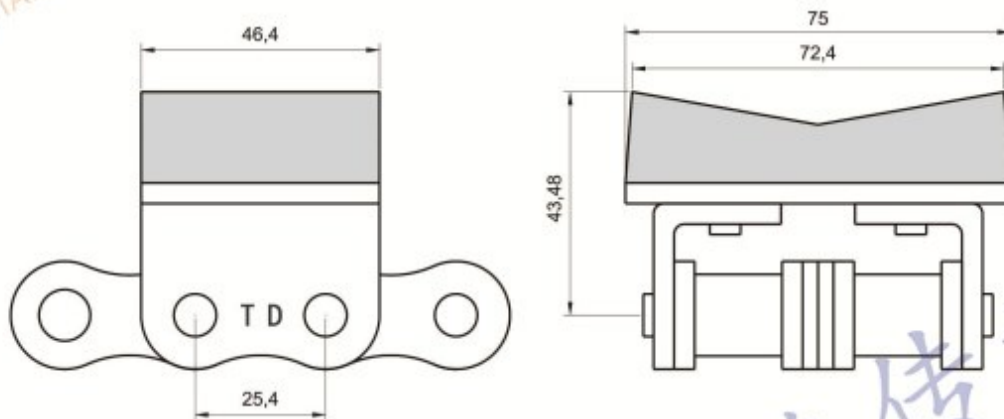

格雷特链传动