

苏州工业园区天地链条有限公司
S. I. P. TIANDI CHAIN Co., Ltd

苏州市格雷特链传动有限公司
SUZHOU GREAT CHAIN TRANSMISSION Co., Ltd

苏州天地链条

输送链专业制造商

since 2004



2019





材质	代码	熔点	使用环境	优点	缺点
聚酰胺-6	PA6	220℃	-30~80℃	弹性好, 有较好的消振, 降噪能力	疲劳强度刚性, 耐热性低于尼龙66
聚己二酰己二胺	PA66	253℃	-30~80℃	疲劳强度和刚性较高, 耐热性较好, 摩擦系数低, 耐磨性好	吸湿性大, 尺寸稳定性不够
聚甲醛	POM	175℃	-40~100℃	较好的机械强度、刚性、疲劳强度、环境抵抗性, 耐有机溶剂性佳、耐反覆冲击性强、良好的电气性质、复原性良好, 具自己润滑性、耐磨性良好、尺寸安定性优。	受强酸腐蚀, 耐候差, 粘性差, 热分解与软化温度接近, 限氧指数小。
聚四氟乙烯 (铁氟龙)	PTFE	327℃	-190~250℃	耐高温、耐低温、具有良好的机械韧性、耐腐蚀、摩擦系数最低、不粘附、	受载时容易出现蠕变现象

其他材质: 10#钢 (冷镦)、45# (车加工)、不锈钢SS201、不锈钢SS304

加工工艺	
冷镦 具有较高的生产率, 大大减少材料消耗, 降低生产成本	车床加工 加工质量稳定、精度高、尺寸随意定制
表面处理	
滚亮抛光	无心磨床 磨外圆
镀镍	镀锌

侧滚轮链条(06B、06C)

Conveyor chains with outboard rollers(06B、06C)



A Type

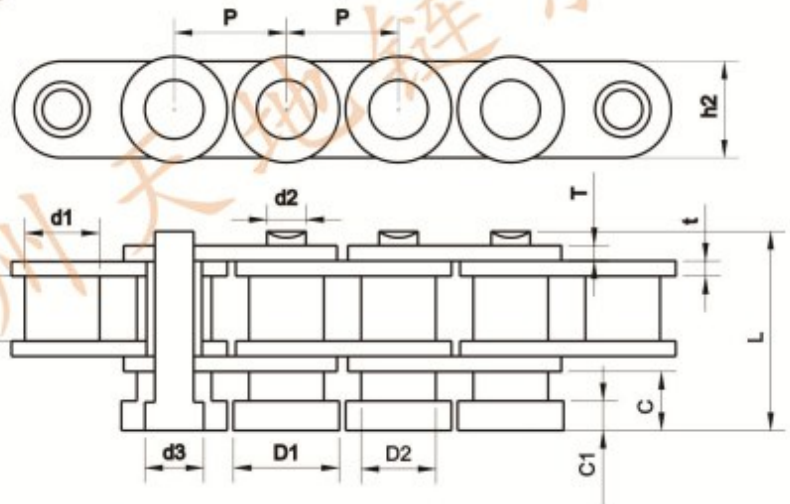

B Type

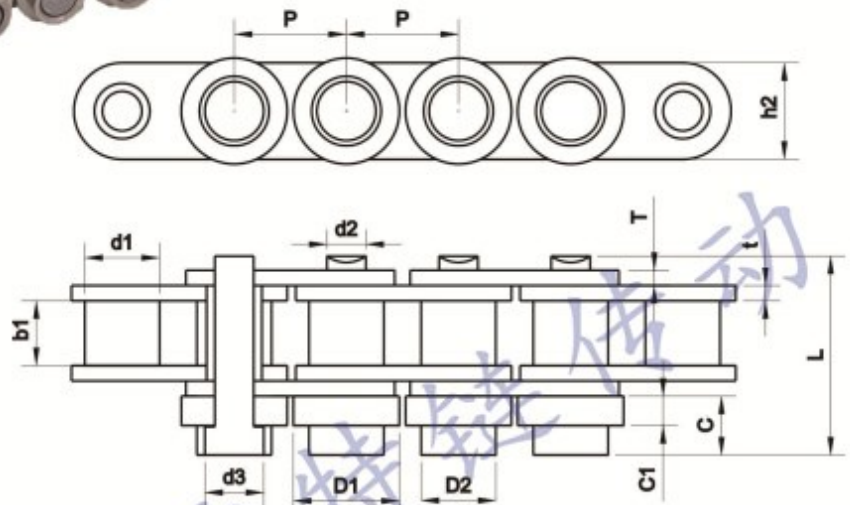

天地链号	节距 Pitch	滚柱直径 Roller diameter	内节内宽 Width between inner plates	销轴直径 Pin diameter	内片宽度 Inner plate depth	链板厚度 Plate thickness	销轴长度 Pin length		滚轮尺寸 Roller dimension			
Chain No.	P	d1	b1	d2	h2	t/T	L	Lc	D1	D2	C1	C
	mm	mm	mm	mm	mm	mm	mm	mm	mm	mm	mm	mm
06C-SR	9.525	5.08	4.77	3.58	9	1.3	16.1	17.1	9	6.35	2.5	5
06B-SR	9.525	6.35	5.72	3.28	8.2	1.3	17.1	18.1	9	6.35	2.5	5
06BF1-SR	9.525	6.35	5.72	3.28	8.2	1.3	18.6	19.6	9	6.35	2.5	6.5
06B-2 SR	9.525	6.35	5.72	3.28	8.2	13	27.2	28.2	9	6.35	2.5	5

滚轮材质：尼龙、碳钢、不锈钢 C1、C尺寸可以定做

Roller material: plastic, 45#, SS201, SS304 The size of C1, C can be customized

侧滚轮链 Conveyor chains with outboard rollers



千鸟型 PSR
Plover type

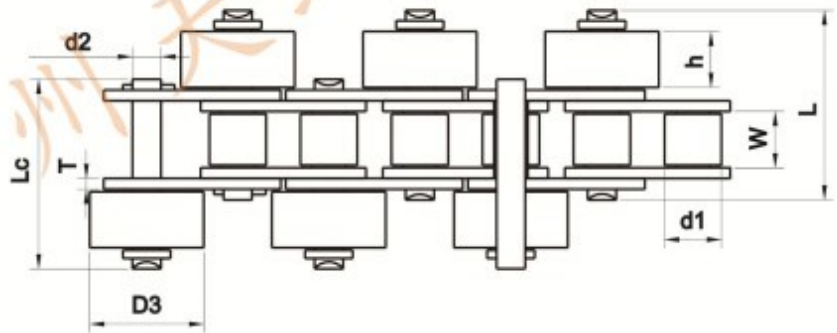

平行型 SSR
Parallel type

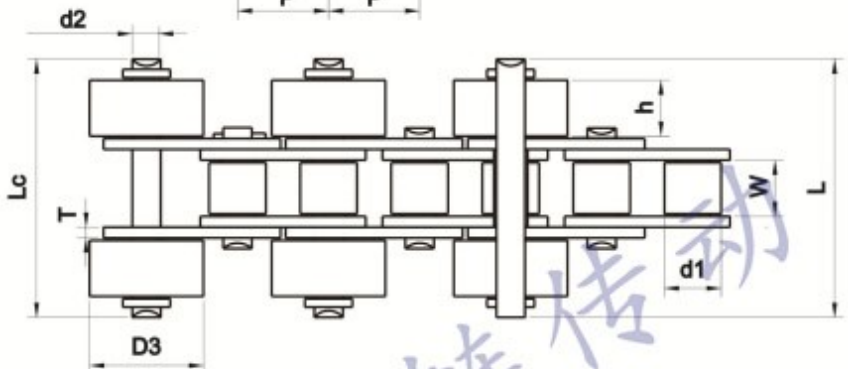
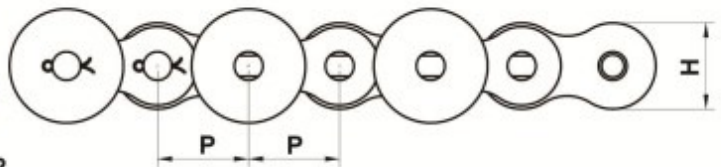

型号	天地链号	节距 Pitch	内节内宽 Width between inner plates	销轴直径 Pin diameter	滚子外径 Roller diameter		滚轮高度 Roller thickness	销轴长度 Pin length		链板尺寸 Plate dimension		每米重量 Weight per max
					d1 max	D3		L	LC	H max	T	
Chain No.	Chain No.	P	W	d2 max	d1 max	D3	h	L	LC	H max	T	kg/m
40-PSR	08A	12.7	7.85	3.96	7.96	15.88	7.6	25.8	27	12	1.5	1.85
40-SSR								34.4	36			
08B-PSR	12.7	7.75	4.45	8.51	15.88	7.6	25.8	27	11.8	1.5	1.85	
08B-SSR												34.3
50-PSR	10A	15.875	9.4	5.08	10.16	19.05	9.2	31.3	33	15.09	2	2.64
50-SSR								41.8	43.5			
60-PSR	12A	19.05	12.57	5.96	11.91	22.23	12.4	39	41	18.08	2.4	3.85
60-SSR								52	55			
80-PSR	16A	25.4	15.88	7.92	15.88	28.58	15.5	49.6	52	24.13	3.2	6.16
80-SSR								66.7	70			
100-PSR	20A	31.75	18.9	9.54	19.05	39.69	19	61.7	65	30.18	4	10.22
100-SSR								83	87			

侧滚轮链(双节距)

Conveyor chains with outboard rollers(double pitch)



千鸟型 PSR
Plover type

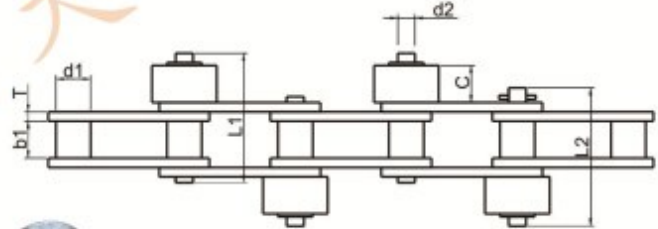
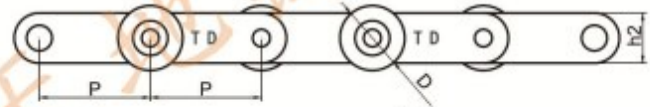

平行型 SSR
Parallel type

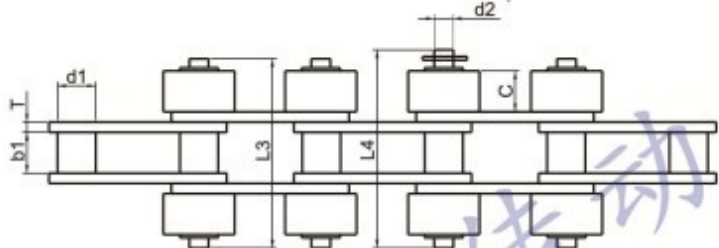
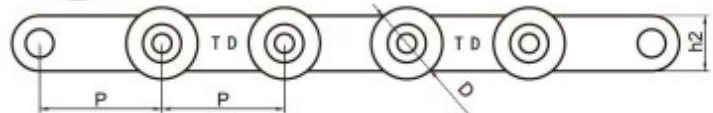

型号	天地链号	节距 Pitch	内节内宽 Width between inner plates	滚子外径 Roller diameter	销轴直径 Pin diameter	销轴长度 Pin length				滚轮尺寸 Roller dimension		链板尺寸 Plate dimension		每米重量 Weight per
Chain No.	Chain No.	P	b1	d1	d2 max	L1	L2	L3	L4	D	C	h2	T	max
		mm	mm	mm	mm	mm	mm	mm	mm	mm	mm	mm	mm	kg/m
C208A	C2040	25.4	7.85	7.95	3.96	25.8	27	34.4	36	15.88	7.6	12	1.5	1.08
C208AL	C2042			15.88						2.31				
C208B		25.4	7.75	8.51	4.45	25.8	27	34.4	36	15.88	7.6	11.8	1.6	1.13
C208BL				15.88						2.36				
C210A	C2050	31.75	9.4	10.16	5.08	31.3	33	41.8	43.5	19.05	9.2	15	2.03	1.55
C210AL	C2052			19.05						3.11				
C212A	C2060	38.1	12.57	11.91	5.94	39	41	52	55	22.23	12.4	18	2.4	2.65
C212AL	C2062			22.23						4.2				
C212AH	C2060H	38.1	12.57	11.91	5.94	42.2	44.2	55.2	58.2	22.23	12.4	18	3.2	2.97
C212AHL	C2062H			22.23						4.52				
C216A	C2080	50.8	15.75	15.88	7.92	49.6	52	66.7	70	28.58	15.5	24	3.2	4.38
C216AL	C2082			28.58						6.88				
C216AH	C2080H	50.8	15.75	15.88	7.92	52.8	55.2	70.2	73	28.58	15.5	24	4	4.84
C216AHL	C2082H			28.58						7.34				
C220A	C2100	63.5	18.9	19.05	9.53	61.7	65	83	87	39.68	18.9	30	4	7.08
C220AL	C2102			39.68						11.49				
C220AH	C2100H	63.5	18.9	19.05	9.53	65.3	68.6	86.2	90.2	39.68	18.9	30	4.8	7.63
C220AHL	C2102H			39.68						12.04				

滚轮材质: 尼龙、碳钢、不锈钢

Roller material: plastic, 45#, SS201, SS304

单侧长销滚轮链

Conveyor chains with outboard rollers and extended pins

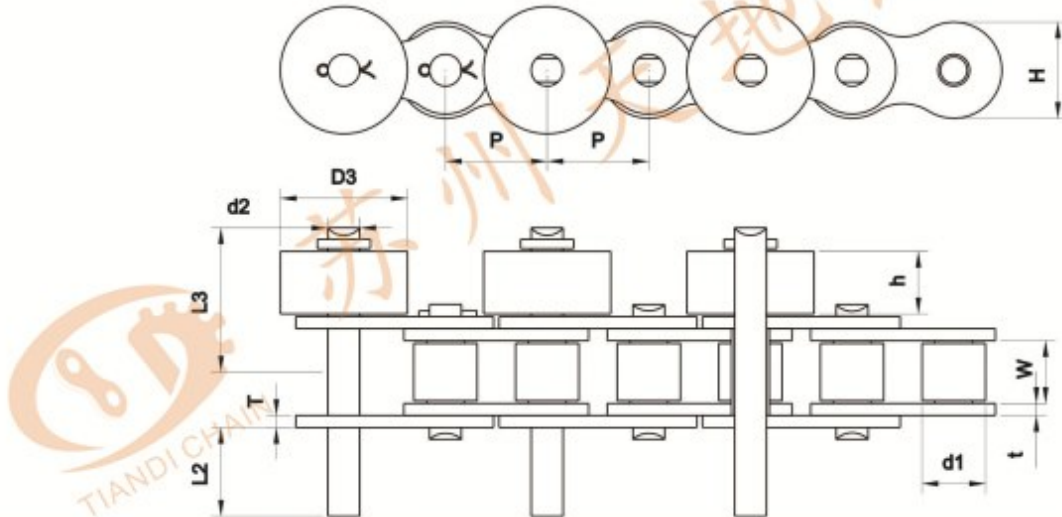

型号	天地链号	节距 Pitch	内节内宽 Width between inner plates	销轴直径 Pin diameter	滚子外径 Roller diameter		滚轮高度 Roller thickness	销轴长度 Pin length		链板尺寸 Plate dimension	
					d1 max	D3		L2 max	L3 max	H max	T
Chain No.	Chain No.	P mm	W mm	d2 max mm	d1 max mm	D3 mm	h mm	L2 max mm	L3 max mm	H max mm	T mm
40	08A	12.7	7.85	3.98	7.92	15.88	7.8	X	19.5	12.07	1.5
	08B	12.7	7.75	4.45	8.51	15.88	7.8	X	19.5	11.8	1.5
50	10A	15.875	9.4	5.08	10.16	19.05	9.4	X	23.5	15.09	2
60	12A	19.05	12.57	5.96	11.91	22.23	12.6	X	30.6	18.08	2.4
80	16A	25.4	15.88	7.92	15.88	28.58	15.8	X	38.2	24.13	3.2
100	20A	31.75	18.9	9.54	19.05	39.69	19	X	45.9	30.18	4

C208A	C2040	25.4	7.85	3.96	7.95	15.88	7.6	X	19.5	12	1.5
C208AL	C2042				15.88	24					
C208B		25.4	7.75	4.45	8.51	15.88	7.6	X	19.5	11.8	1.6
C208BL					15.88	24					
C210A	C2050	31.75	9.4	5.08	10.16	19.05	9.4	X	23.5	15	2.03
C210AL	C2052				19.05	27					
C212A	C2060	38.1	12.57	5.94	11.91	22.23	12.6	X	30.6	18	2.4
C212AL	C2062				22.23	30					
C212AH	C2060H	38.1	12.57	5.94	11.91	22.23	12.6	X	32.2	18	3.2
C212AHL	C2062H				22.23	30					
C216A	C2080	50.8	15.75	7.92	15.88	28.58	15.7	X	38.2	24	3.2
C216AL	C2082				28.58	38					
C216AH	C2080H	50.8	15.75	7.92	15.88	28.58	15.7	X	39.8	24	4
C216AHL	C2082H				28.58	38					
C220A	C2100	63.5	18.9	9.53	19.05	39.68	18.9	X	45.9	30	4
C220AL	C2102				39.68	50					
C220AH	C2100H	63.5	18.9	9.53	19.05	39.68	18.9	X	47.5	30	4.8
C220AHL	C2102H				39.68	50					

特殊滚轮链

Conveyor chains with special rollers

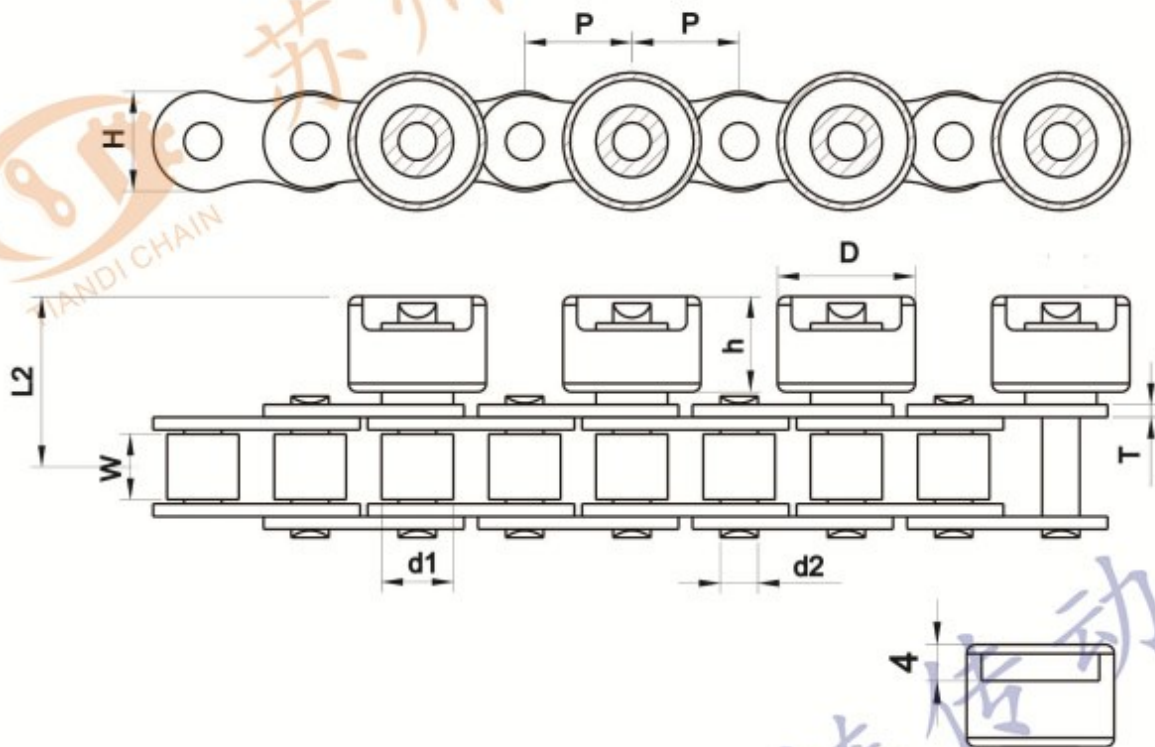

型号	天地链号	节距 Pitch	内节内宽 Width between inner plates	销轴直径 Pin diameter	滚子外径 Roller diameter	滚轮高度 Roller thickness	销轴长度 Pin length	链板尺寸 Plate dimension		每米重量 Weight per	
Chain No.	Chain No.	P	W	d2 max	d1 max	D3	h	L2 max	H max	T	max
		mm	mm	mm	mm	mm	mm	mm	mm	mm	kg/m
40	08A	12.7	7.85	3.98	7.92	15.88	11.3	18.5	12.07	1.5	1.85
	08B	12.7	7.75	4.45	8.51	15.88	11.3	18.5	11.8	1.5	1.85
50	10A	15.875	9.4	5.08	10.16	19.05	13	22	15.09	2	2.64
60	12A	19.05	12.57	5.96	11.91	22.23	16.2	27.5	18.08	2.4	3.85
80	16A	25.4	15.88	7.92	15.88	28.58	19.5	34	24.13	3.2	6.16
100	20A	31.75	18.9	9.54	19.05	39.69	23	41	30.18	4	10.22

顶滚轮链

Conveyor chains with top rollers

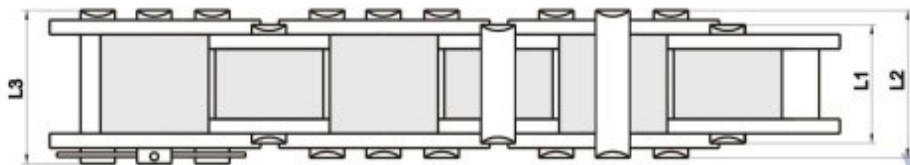
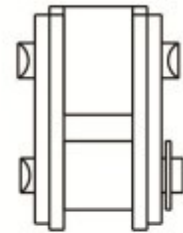
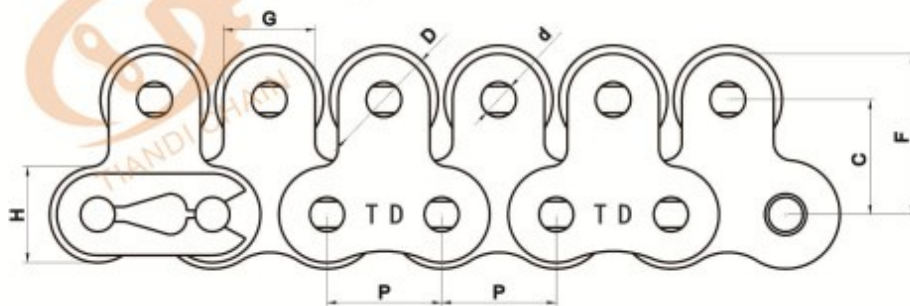

型号	天地链号	节距 Pitch	滚轮直径 Roller diameter	销轴直径 Pin diameter	附板尺寸 Attachment dimension				销轴长度 Pin length			极限抗拉强度 Ultimate tensile strength	每米重量 Weight per meter
					G	C	F	H	L1 max	L2 max	L3 max		
Chain No.	Chain No.	P mm	D mm	d max mm	mm	mm	mm	mm	mm	mm	mm	Q min kN/lbf	q kg/m
40-TR	08A-TR	12.7	11	3.96	9.5	12.7	17.45	12	13.5	16.6	17.8	14.4/3250	1.44
	08AF1-TR	12.7	11	3.96	9.5	15.7	20.45	12	13.5	16.6	17.8	14.4/3250	1.47
	08B	12.7	11	4.45	9.5	12.7	17.45	12	13.5	16.7	17.8	18/4091	1.5
50-TR	10A-TR	15.875	15	5.08	12.7	15.9	22.25	15	16.5	20.7	22.2	22.2/5405	2.3
60-TR	12A-TR	19.05	18	5.94	15.9	18.3	26.25	18.1	21	25.9	27.7	31.8/7227	3.4
80-TR	16A-TR	25.4	24	7.92	19.1	24.6	34.15	24.1	26.2	32.7	35	56.7/12886	5.9
100-TR	20A-TR	31.75	30	9.53	25.4	31.8	31.1	30.1	32.3	40.4	44.7	88.5/20114	8.9

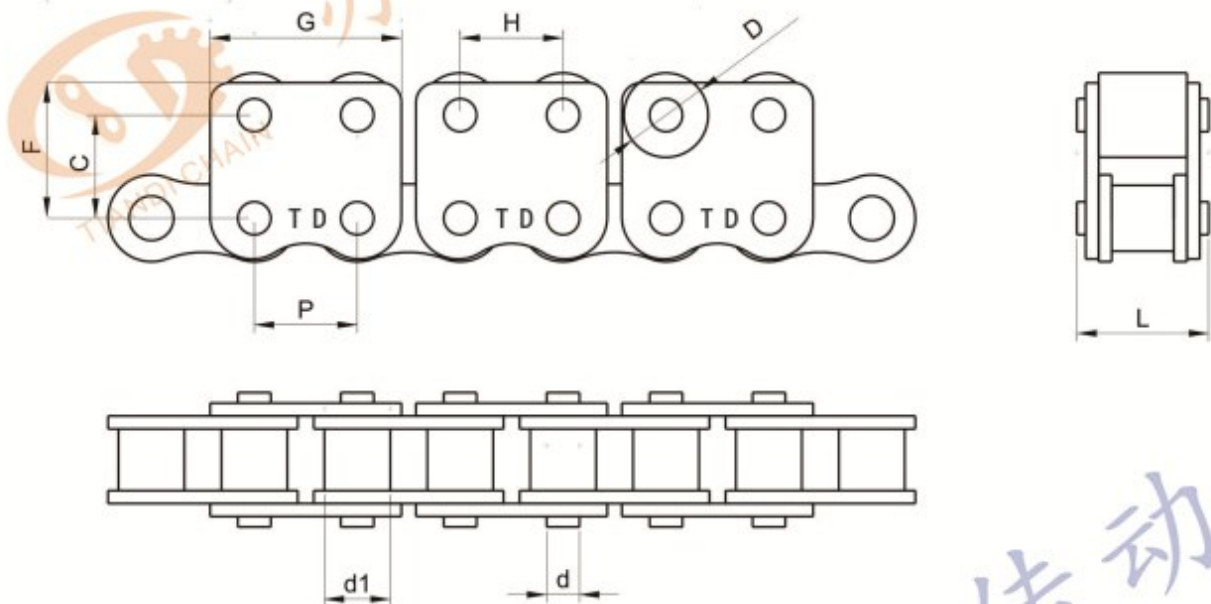

天地链号	节距 Pitch	滚轮直径 Roller diameter		销轴直径 Pin diameter	销轴长度 Pin length	附板尺寸 Attachment dimension			
Chain No.	P	d1	D	d max	L	G	C	F	H
	mm	mm	mm	mm	mm	mm	mm	mm	mm
06B-WTR	9.525	6.35	10	3.28	13.2	17.8	10	13.5	-
06B-F1-WTR	9.525	6.35	9	3.28	13.2	17.6	9.5	13	9.525
08B-WTR	12.7	8.51	12	4.45	16.6	23	13.7	18.9	12.7
10A-WTR	15.875	10.16	13	5.08	20.7	28.8	15.9	23	15.88
16A-WTR	25.4	15.88	24	7.94	32.7	45.4	25	35	25.4
*16B-WTR	25.4	15.88	15	5.08	36.1	45.4	19.9	25.9	16.5

顶滚轮链(双节距) Conveyor chains with top rollers(double pitch)

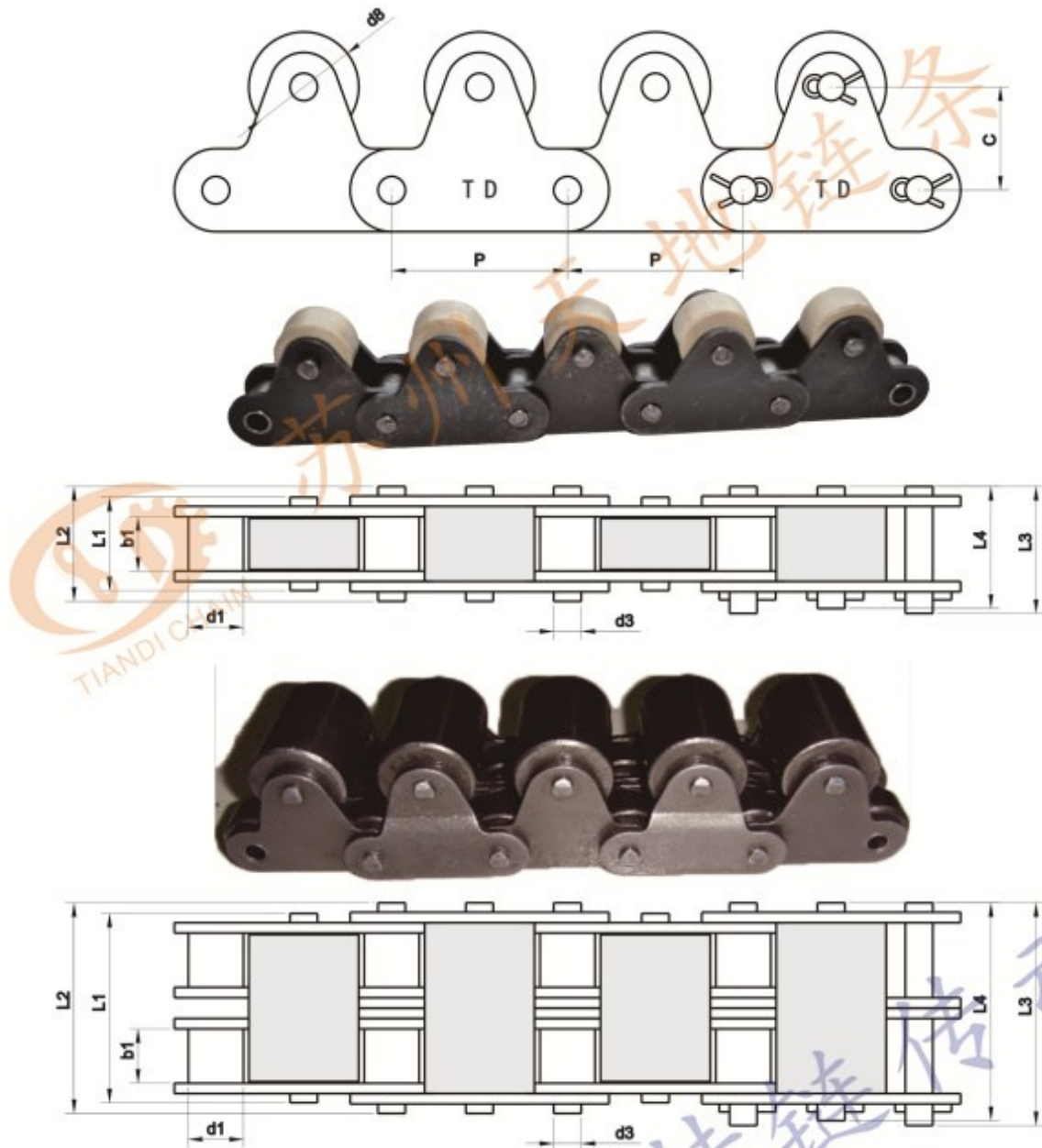

天地链号 Chain No.	节距 Pitch P	滚柱直径 Roller diameter		内节内宽 Width between inner plates		销轴直径 Pin diameter		销轴长度 Pin length				附板尺寸 Attachment dimension	极限抗拉强度 Ultimate tensile strength	每米重量 Weight per meter
		d1 max	d8 max	b1 min	d3 max	L1 max	L2 max	L3 max	L4 max	C	Q min	q		
	mm	mm	mm	mm	mm	mm	mm	mm	mm	mm	mm	kN/lbf	kg/m	
C2040-1LTR	25.4	7.95	15.88	7.85	3.96	13.5	16.6	18.8	17.8	12.7/15	14.1/3205	1.31		
C2040-F1	25.4	7.95	15.88	7.85	3.96	13.5	16.6	18.8	17.8	31	14.1/3205	1.6		
C2050-1LTR	31.75	10.16	19.05	9.4	5.08	16.5	20.7	23.3	22.2	15.9/19	22.2/5045	2.03		
C2060-1LTR	38.1	11.91	22.23	12.57	5.94	21	25.9	28.3	27.7	18.3/24	31.8/7227	2.89		
C2080-1LTR	50.8	15.88	28.58	15.75	7.92	26.2	32.7	36.5	35	29/24.6	56.7/12886	4.54		
C2100-1LTR	63.5	19.05	39.67	18.9	9.53	32.3	40.4	44.7	44.7	35.4/31.8	88.5/20114	7.72		
C208B-2LTR	25.4	8.51	15.88	7.75	4.45	28	31	33	31	12.7/15	14.1/3205	2.62		
C2050-2LTR	31.75	10.16	19.05	9.4	5.08	35.1	39.06	40.7	39.1	15.9/19	22.2/5045	4.06		
C2060H-2LTR	38.1	11.91	22.23	12.57	5.94	48.5	54.9	56.9	54.9	18.3/24	31.8/7227	5.78		
C2080H-2LTR	50.8	15.88	28.58	15.75	7.92	60.2	68.2	71.2	68.2	29/24.6	56.7/12886	9.08		
C2100-2LTR	63.5	19.05	38	18.9	9.53	68.4	76.4	80.4	76.4	35.4/31.8	88.5/20114	15.44		

A Type



B Type

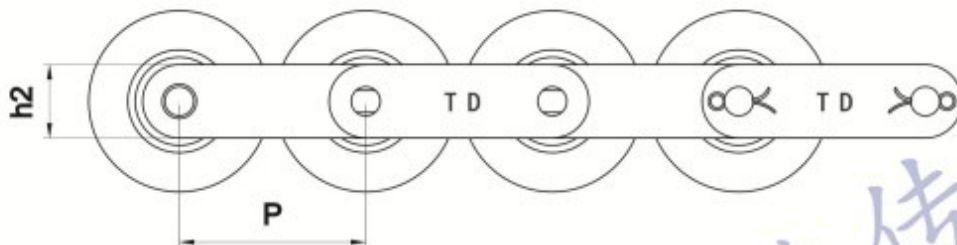
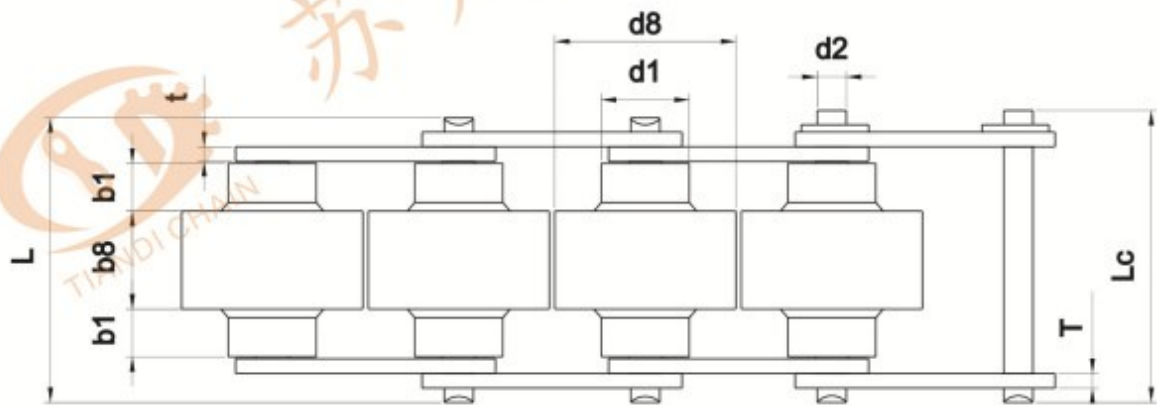

天地链号	链号	节距 Pitch	滚子尺寸 Roller dimension				销轴尺寸 Pin dimension			链板尺寸 Plate dimension			每米重量 Weight per meter
Chain No.	NO.	P	d1 max	d8 max	b1 max	b8 max	d2 max	L max	Lc max	h2 max	T max	t max	q
		mm	mm	mm	mm	mm	mm	mm	mm	mm	mm	mm	kg/m
BS10-C212A		38.1	18	37	9.75	20	5.94	58.1	62.7	15	3	4	2.14
BS10-C212AF1		38.1	22.23	36.6	8.5	15.5	5.94	48.8	51.5	18	3	3	2.19
BS25-C206B	C2030W	19.05	11.91	18.3	4	8	3.28	24	25.6	8.26	1.3	1.5	0.52
BS25-C208A	C2040W	25.4	15.88	24.6	5.7	10.3	3.96	31	32.8	11.7	1.5	1.5	0.79
BS25-C210A	C2050W	31.75	19.05	30.6	7.1	13	5.08	39.5	41.2	15	2.06	2.06	1.36
BS25-C212A	C2060HW	38.1	22.23	36.6	8.5	15.5	5.94	48.8	50.5	18	3.25	3.25	2.19
BS25-C216A	C2080W	50.8	28.58	49	11	21.5	7.92	66.2	70	24	4	5	4.06
BS30-C206B		19.05	9	18.3	4.5	9.1	3.28	26.3	29.6	7.28	1.3	1.5	0.5
BS30-C208A		25.4	11.91	24.6	6.1	12.5	3.96	35.6	39.5	9.6	1.5	2	0.83
BS30-C210A		31.75	14.8	30.6	7.5	15	5.08	43	47.1	12.2	2	2.4	1.27
BS30-C212A		38.1	18	37	9.75	20	5.94	58.1	62.7	15	3	4	2.14
BS30-C216A		50.8	22.23	49	12	25.2	7.92	71.9	77.3	18.6	4	5	3.55

三排倍速链 Double plus chains (triplex)

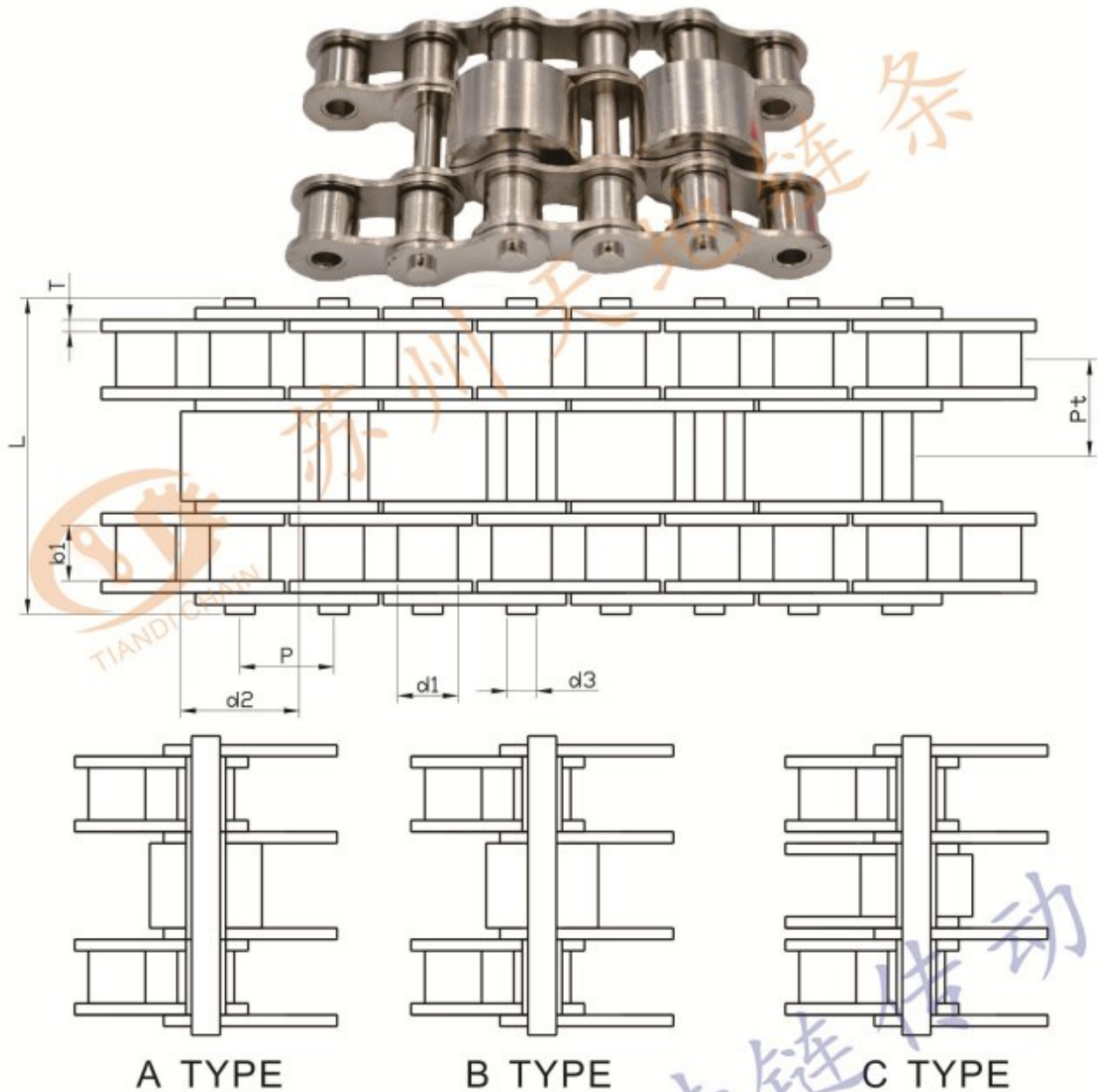

天地链号	节距 Pitch	滚柱直径 Roller diameter		内节内宽 Width between inner plates	销轴尺寸 Pin size		链板厚度 Plate thickness	排距 Transverse pitch	极限抗拉强度 Ultimate tensile strength	平均抗拉强度 Average tensile strength
Chain No.	P	d1 max	d2	b1 min	d3	L	t/T	Pt	Q min	Q0
	mm	mm	mm	mm	mm	mm	mm	mm	kN/lbf	kN
06BS-3-C14/P14	9.525	6.35	14	5.72	3.28	33.5	1.3	10.24	14/3147	16.1
06BS-3-C15/P15	9.525	6.35	15	5.72	3.28	33.5	1.3	10.24	16.9/3841	18.7
08BS-3-45-C16	12.7	8.51	16	7.75	4.45	45.1	1.5	13.92	32/7273	38.7
08BS-3-45-C17	12.7	8.51	17	7.75	4.45	45.1	1.5	13.92	32/7273	38.7
08BS-3-45-C20	12.7	8.51	20	7.75	4.45	45.1	1.5	13.92	32/7273	38.7
12AS-3-65-C28	19.05	11.91	28	12.57	5.94	65.3	2.4	19.6	62.3/14005	71.6
12BS-3-62-C26	19.05	12.07	26	11.68	5.72	61.5	1.85	19.46	57.8/12993	66.1
12BS-3-62-C28	19.05	12.07	28	11.68	5.72	61.5	1.85	19.46	57.8/12993	66.1
12BS-3-62-C31	19.05	12.07	31	11.68	5.72	61.5	1.85	19.46	57.8/12993	66.1
16BS-3-100-C35	25.4	15.88	35	17.02	8.28	100	4.15/3.1	31.88	160/35968	184
16BS-3-100-C38	25.4	15.88	38	17.02	8.28	100	4.15/3.1	31.88	160/35968	184

P代表塑料滚轮 C代表碳钢滚轮

双侧滚轮倍速链

Double plus chains with two side rollers

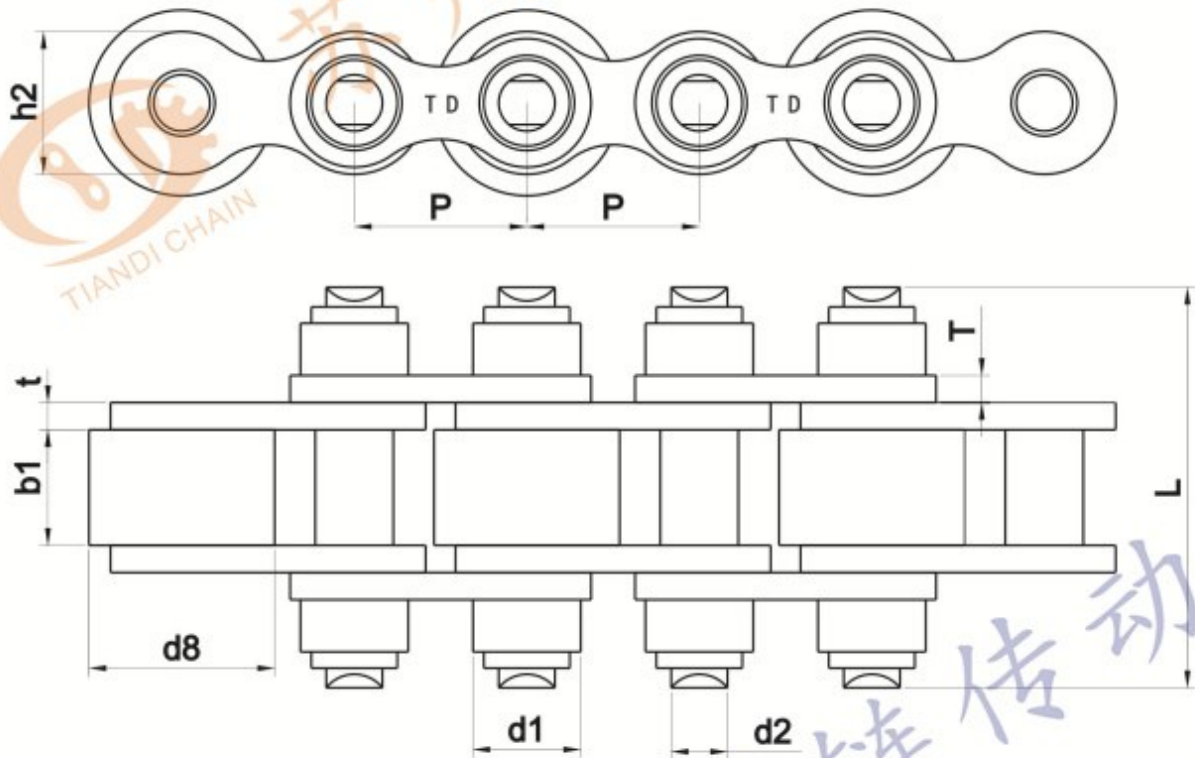

天地链号	节距 Pitch	滚轮直径 Roller diameter		内节内宽 Width between inner plates	销轴直径 Pin diameter	销轴长度 Pin length	链板尺寸 Plate dimension		极限抗拉强度 Ultimate tensile strength	平均抗拉强度 Average tensile strength
Chain No.	P	d1 max	d8 min	b1 min	d2 max	L max	h2 max	t/T max	Q min	Q0
	mm	mm	mm	mm	mm	mm	mm	mm	kN/lbf	kN
08BS-27-P16/C16	12.7	8.51	16	7.75	4.45	27	11.8	1.6/1.5	18.0/4091	19.8
08BS-31-P16/C16	12.7	8.51	16	7.75	4.45	31	11.8	1.6/1.5	18.0/4091	19.8
12BS	19.05	12.07	28	11.68	5.72	45	16	1.85	28.9/6568	31.7
12BS-40-P28/C28	19.05	12.07	28	11.68	5.72	40	16	1.85	29.0/6591	31.7
12BS-43-P26/C26	19.05	12.07	26	11.68	5.72	43	16	1.85	29.0/6592	31.7
12BS-43-P28/C28	19.05	12.07	28	11.68	5.72	43	16	1.85	29.0/6593	31.7
12BS-48-P24/C24	19.05	12.07	24	11.68	5.72	48	16	1.85	29.0/6594	31.7
12BS-48-P26/C26	19.05	12.07	26	11.68	5.72	48	16	1.85	29.0/6595	31.7
12BS-48-P28/C28	19.05	12.07	28	11.68	5.72	48	16	1.85	29.0/6596	31.7
16BS-65-P38/C38	25.4	15.88	38	17.02	8.28	65	21	4.15/3.1	60.0/13636	72.8
212BS-43-P24	38.1	12.07	24	11.68	5.72	43	16	1.85	28.9/6568	31.7

P代表塑料滚轮 C代表碳钢滚轮

P means roller made in plastic C means roller made in steel www.tdchain.com

双侧滚轮倍速链

Double plus chains with two side rollers

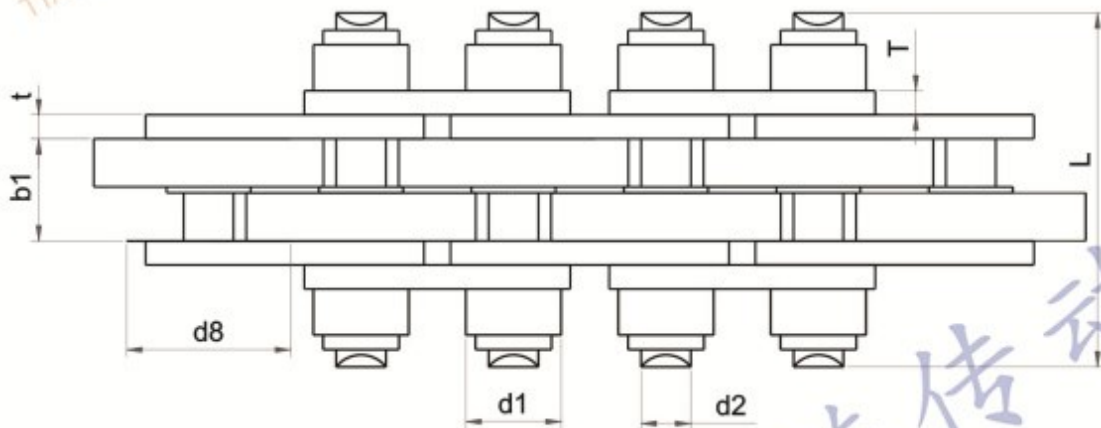
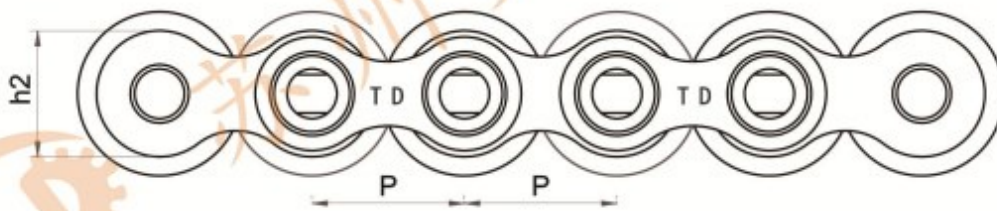

天地链号	节距 Pitch	滚轮直径 Roller diameter		内节内宽 Width between inner plates	销轴直径 Pin diameter	销轴长度 Pin length	链板尺寸 Plate dimension		极限抗拉强度 Ultimate tensile strength	平均抗拉强度 Average tensile strength
Chain No.	P	d1 max	d8 min	b1 min	d2 max	L max	h2 max	t/T max	Q min	Q0
	mm	mm	mm	mm	mm	mm	mm	mm	kN/lbf	kN
08BS-27-P16/C16	12.7	8.51	16	7.75	4.45	27	11.8	1.6/1.5	18.0/4091	19.8
08BS-31-P16/C16	12.7	8.51	16	7.75	4.45	31	11.8	1.6/1.5	18.0/4091	19.8
12BS	19.05	12.07	28	11.68	5.72	45	16	1.85	28.9/6568	31.7
12BS-40-P28/C28	19.05	12.07	28	11.68	5.72	40	16	1.85	29.0/6591	31.7
12BS-43-P26/C26	19.05	12.07	26	11.68	5.72	43	16	1.85	29.0/6592	31.7
12BS-43-P28/C28	19.05	12.07	28	11.68	5.72	43	16	1.85	29.0/6593	31.7
12BS-48-P24/C24	19.05	12.07	24	11.68	5.72	48	16	1.85	29.0/6594	31.7
12BS-48-P26/C26	19.05	12.07	26	11.68	5.72	48	16	1.85	29.0/6595	31.7
12BS-48-P28/C28	19.05	12.07	28	11.68	5.72	48	16	1.85	29.0/6596	31.7
16BS-65-P38/C38	25.4	15.88	38	17.02	8.28	65	21	4.15/3.1	60.0/13636	72.8
212BS-43-P24	38.1	12.07	24	11.68	5.72	43	16	1.85	28.9/6568	31.7

P代表塑料滚轮 C代表碳钢滚轮

P means roller made in plastic C means roller made in steel

三排倍速链

Double plus chains (triplex)

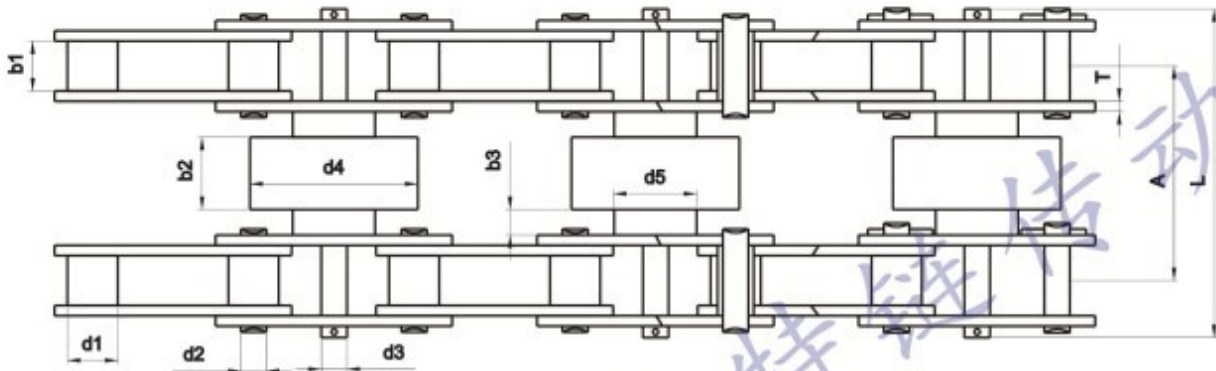
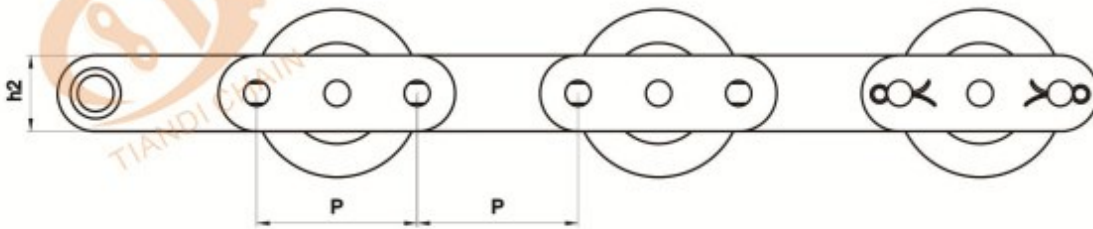

天地链号	节距 Pitch	内节内宽 Width between inner plates	滚柱直径 Roller diameter			滚珠高度 Roller height		销轴尺寸 Pin size			链板尺寸 Plate size		排距 Transve rse pitch	极限抗拉强度 Ultimate tensile strength
Chain No.	P	b1 min	d1	d4	d5	b2	b3	d2	d3	L	h	t/T	Pt	Q min kN/lbf
	mm	mm	mm	mm	mm	mm	mm	mm	mm	mm	mm	mm	mm	
C208A-BS25	25.4	7.85	7.95	30.6	19.05	13	7.1	3.96	5.08	65.5	12.07	1.5	42	14.1/3205
C210A-BS25	31.75	9.4	10.16	36.6	22.23	15.5	8.5	5.08	5.94	76.7	15.09	2	51	22.4/5091

边滚轮链

Conveyor chains with side rollers



A Type

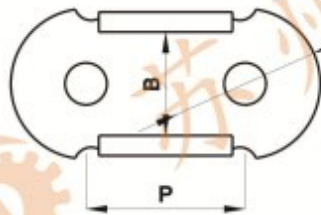

B Type

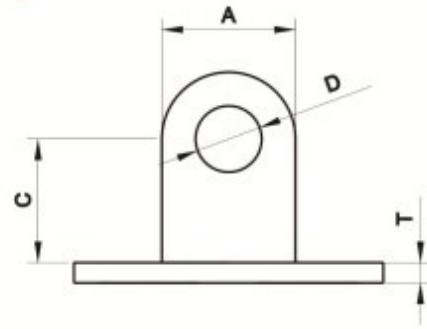

天地链号 Chain No.	节距 Pitch	附板尺寸 Attachment size					
	P	A	B	C	D	H	T
	mm	mm	mm	mm	mm	mm	mm
08B	12.7	11.8	10	10	4.45	10.3	1.5
12AF1	19.05	16	12.4	14.8	7.92	18	2.42
12AF2	19.05	12	9	10	3.28	13.5	2.42
16AF1	25.4	13.8	20.6	12.1	5.94	20	3
16AF2	25.4	15	21.4	18	5.94	20	3
16AF3	25.4	16	22.5	14	5.94	21.2	3
16AF4	25.4	16	20	10	7.92	21.2	3
C2040	25.4	11	10	10	3.96	11.8	1.5
C2040-F1	25.4	11	8.1	12	3.96	11.8	1.5
*C2050	31.75	12	8	7.8	5.08	15	2
C2060	38.1	18	15.4	17.6	10	18	2.42
C212B	38.1	50.8	13.8	6.6	5.72	16	1.85
C2080	50.8	18.2	18	12.9	7.92	23.2	3.25
*C2080-F1	50.8	16	12.2	17	8.1	24	3

10A

